

DIGITAL TECHNOLOGY IMPLEMENTATION OF PEAK CURRENT CONTROL METHOD WITH PID COMPENSATOR APPLIED TO BUCK CONVERTER

Octavian BOTEZ Mihai LUCANU Ovidiu URSARU Cristian AGHION

"Gheorghe Asachi" Technical University, Faculty of Electronics, Telecommunications and Information Technology,
Bvld. Carol I, No. 11, 700506, Iasi, Romania

e-mail: obotez@etti.tuiasi.ro, mlucanu@etti.tuiasi.ro, ovidiu@etti.tuiasi.ro, aghion@etti.tuiasi.ro

Abstract: Lately, digital control technology has advanced greatly in the field of power electronics[14], enabling implementation of more and more common method to control electronic converters. This paper presents the modeling and the simulation of peak current control method with PID compensator, applied to a synchronous buck converter with digital control, and its practical implementation. For simulation, the C language source code was designed for the perturbations compensating function, the duty cycle calculation applied to PWM generator, and variable current reference.

Keywords: peak current, PID compensator, synchronous buck, digital technology.

I. INTRODUCTION

Modeling and simulation of peak current method applied to synchronous buck converter [11]-[13] was developed in Matlab Simulink R2010a program, and the practical implementation by using a DSP from Microchip dsPIC33FJ16GS502[1]-[4]. The block diagram of principle from which we started implementing the control method is shown in Fig. 1 [5], [6]. The switching frequency of MOSFET transistors was chosen 50kHz. The DC voltage applied to the converter at the input was 28V and output was dimensioned so that the output would be a stabilized voltage of 12V. To stress the converter up to 288W, the load resistor chosen was 0.5Ω. To analyze performance of control method, we will vary quickly the load resistor from 100Ω to 0.5Ω and vice versa, thus obtaining a variable power output from 1.44W to 288W, and vice versa.

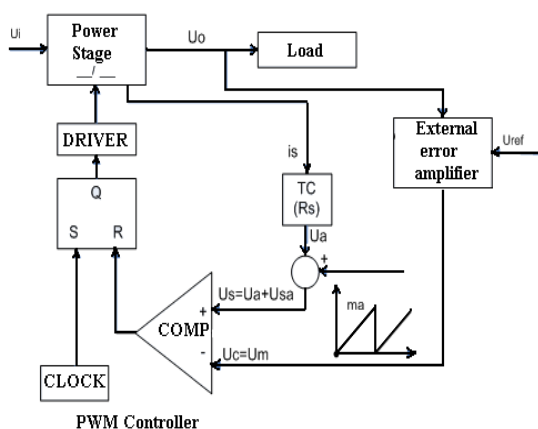

Figure 1. The block diagram of peak current control

II. MODELING CONVERTER COMMAND

The simulated scheme of control method applied to the buck converter is shown in Fig.2 [8]-[10]. All the built blocks in Matlab Simulink were chosen based on existing functional blocks in DSP to simulate with more accurately the real case, and perturbations compensation logic from output and calculated duty cycle applied to the PWM generator were implemented using a software function coded in C language.

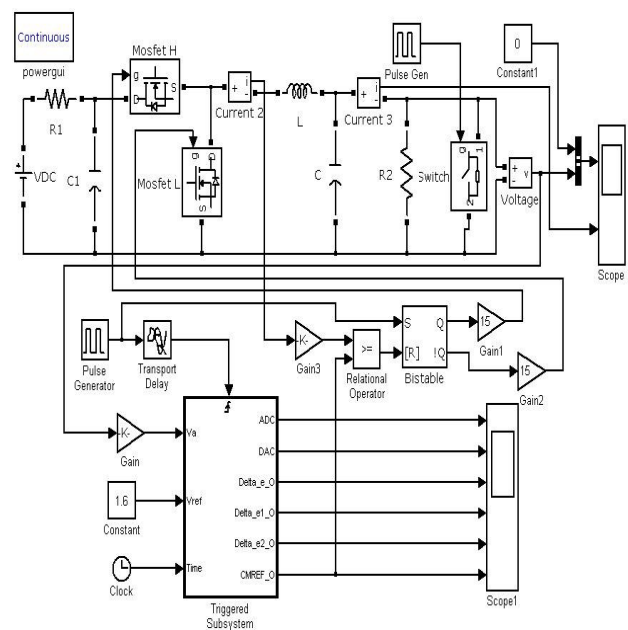

Figure 2: Simulation scheme.

The "High Speed PWM"[4] bloc working in a complementary way was modeled using the "Bistable" block. The "High Speed Comparator"[4] block was implemented using the "Relational Operator" block that makes the comparison between the signal from the block "Gain2", which represents the inductor current divided suitable, and the variable current reference signal from the "CMREF_O", which shapes the DAC block within the DSP[4]. Modeling the PID function for compensating the output perturbations, calculation of duty cycle applied to the PWM generator, the variable current reference and DAC block have been implemented using "Triggered B subsystem" block, inside which there is "MATLAB Embedded Function" block, represented in Fig. 3, in which the function is written in C language. The ADC circuit inside the DSP[4] was modeled with the "Sample & Hold" block (Fig. 3), and using "Transport Delay" block (Fig. 2) were modeled triggering sampling time of ADC, against of rising edge time of MOSFET switch from high side, plus specific converting time delay of ADC[4], which in this example is 1us from switching time plus 1us of time during the conversion. The triggering frequency of the "Triggered B subsystem" block is equal to the transistor switching frequency. The quick variation of load resistance from 0.5Ω to 100Ω and vice versa, was achieved by connecting in parallel with the load resistance a switch with 0.5Ω contact resistance, its switching being achieved through pulse generator.

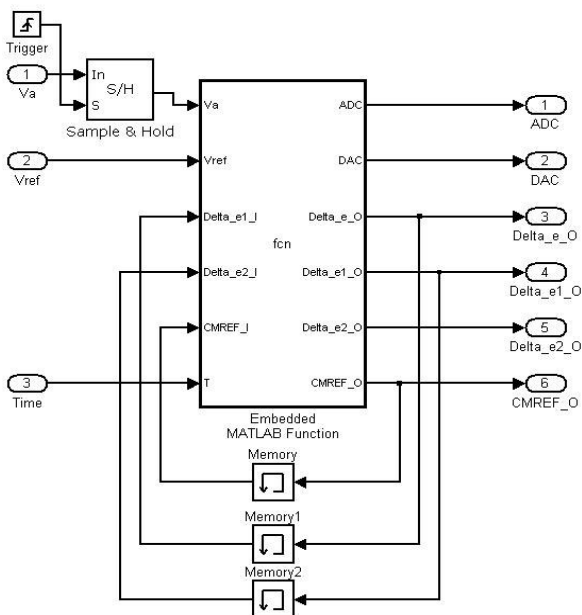

Figure 3: Content of "Triggered B subsystem" block.

For digital implementation, we use parallel form of PID function:

$$u(t) = K_p e(t) + K_i \int_0^t e(\tau) d\tau + K_d \frac{d}{dt} e(t) \quad (1)$$

Applying the Z transform of this function we get:

$$U(z) = \left[K_p + \frac{K_i}{1-z^{-1}} + K_d(1-z^{-1}) \right] E(z) \quad (2)$$

Rearranging gives:

$$U(z) = \left[\frac{(K_p + K_i + K_d) + (-K_p - 2K_d)z^{-1} + K_d z^{-2}}{1-z^{-1}} \right] E(z) \quad (3)$$

From (2) and (3) gives:

$$K_1 = K_p + K_i + K_d$$

$$K_2 = -K_p - 2K_d \quad (4)$$

$$K_3 = K_d$$

(7) can be rewritten as:

$$U(z) - z^{-1}U(z) = [K_1 + K_2 z^{-1} + K_3 z^{-2}] E(z) \quad (5)$$

Which then converted back to difference equation as:

$$u[k] = u[k-1] + K_1 e[k] + K_2 e[k-1] + K_3 e[k-2] \quad (6)$$

The source code written in C language, contained in "Embedded Fuction MATLAB" block for implementations of an embeded PID function, is presented below:

```
% Outputs                               Inputs
function [ADC, DAC, Delta_e_O, Delta_e1_O,
Delta_e2_O, CMREF_O] = fcn(Va, Vref, Delta_e1_I,
Delta_e2_I, CMREF_I, T)
```

```
kp = 25;
ki = 19.5;
kd = 4.5;
```

```
k1 = kp+ki+kd;
k2 = -kp-2*kd;
k3 = kd;
```

```
Delta_e1_O = Delta_e1_I;
Delta_e2_O = Delta_e2_I;
```

```
Temp_Vref = Vref;
Temp_ADC = Va;
Temp_CMREF_I = CMREF_I;
Current_limit_M = 48;
```

```
if (T <= 0.01)
    Temp_Vref = 0.8;
end
```

```
Temp_Delta_e = Temp_Vref - Temp_ADC;
Delta_e_O = Temp_Delta_e;
Temp_Delta_U = k1*Temp_Delta_e + k2*Delta_e1_I +
k3*Delta_e2_I;
Temp_CMREF_O = Temp_CMREF_I + Temp_Delta_U;
```

```
if(Temp_CMREF_O < 0)
    Temp_CMREF_O = 0;
end
```

```
if(Temp_CMREF_O > Current_limit_M)
    Temp_CMREF_O = Current_limit_M;
end
```

```
CMREF_O = Temp_CMREF_O;
```

```

ADC = Va;
DAC = CMREF_I;
end
    
```

III. SIMULATION RESULTS

At a load variation from 0W to 288W, and vice versa, the waveforms for the voltage and current of the load resistance are represented in Fig.4. Note that at a quick variation of load from 0 to 288W, equivalent to a current variation from 0A to 24A, the output voltage ripple amplitude is 0.9V, followed by some oscillations, compensated in about 0.9ms. The load variation from 288W to 0, equivalent to a current variation from 24A to 0A, has a positive ripple voltage of 0.9V, which is amortized linearly in about 1.25ms. These ripples are found proportionally in a load current.

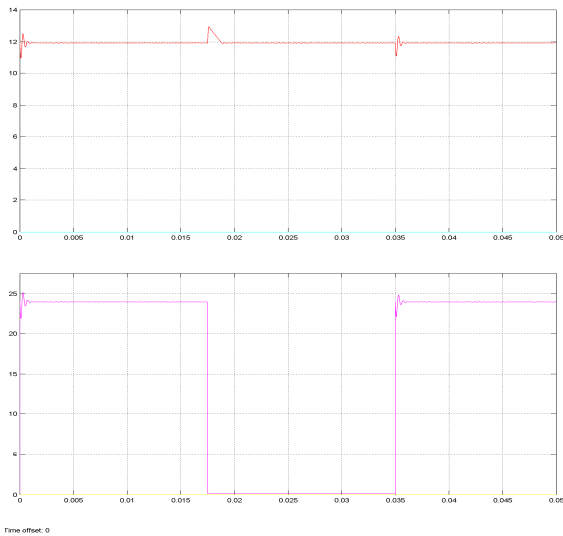

Fig. 4 : Wave forms for the voltage and current of the load resistance plotted in Matlab.

IV. PRACTICAL REALIZATION

The practical scheme achieved is presented in Fig.5. We observe the MOSFET transistors IRF3205 with snubber circuits associated, controlled by drivers with optical isolation HCPL3120, for good command of entrance in conduction and blocking the conduction of the transistors. The current sensor is LA 25-NP, connected in series with the inductor of converter, to collect a signal as clean as possible in terms of noise. For the electronic relay that switch the load resistance of 0.5Ω is used a MOSFET transistor IRF3205 with snubber circuit associated, commanded through TC4427 driver. The function that performs the PID logic compensation of output perturbation, applied to calculate the duty cycle for PWM generator, and variable current reference and DAC block, is called in ADC interrupt routine block, with a delay of 2μs from the rising edge moment of the High Side transistor conduction, delay used for sampling signals as clean after switching specific oscillations disappear. The frequency of interrupt routine is equal to converter switching frequency 50kHz. The source code written in C of this routine is almost identical to the one written in Matlab Simulink and therefore was not presented. Picture of practical installation is shown in Fig. 6.

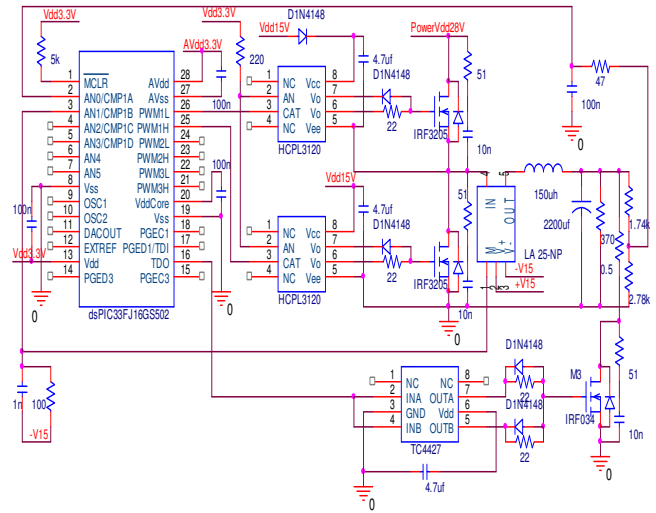

Figure 5: The practical scheme.

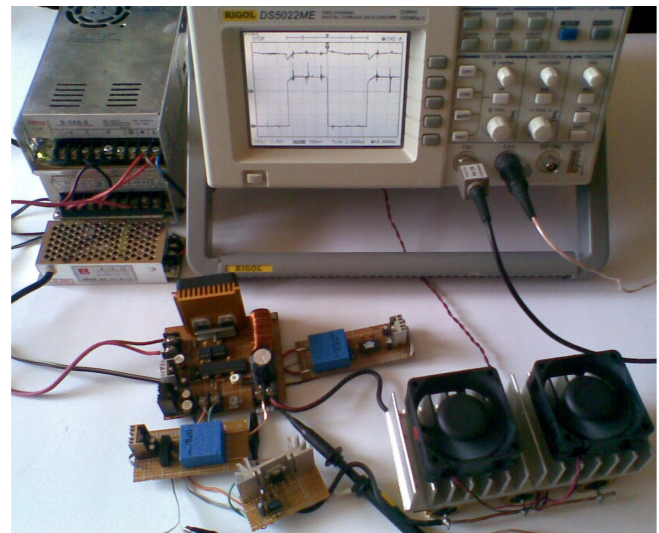

Figure 6: Practical installation picture.

V. PRACTICAL RESULTS

In practice, even if the same load resistance of 0.5Ω was used, due to contact resistance and cables, was obtain a variance from 0A to 21A, and reverse, the equivalent variation of power from 0W to 252W and vice versa. The electronic switch was built using a power MOSFET transistor to eliminate the switch oscillations, specific for mechanical switches, and to ensure more vertical fronts at times switching. Waveforms of voltage and current from load resistance are presented in Fig.7. Note that at a load variation from 0 to 288W, the negative ripple amplitude of the output voltage is 0.7V , compensated in about 1ms. At a load variation from 288W to 0% there is a positive ripple of 0.4V voltage, compensated linearly in about 2ms. These ripples are found proportionally in load current.

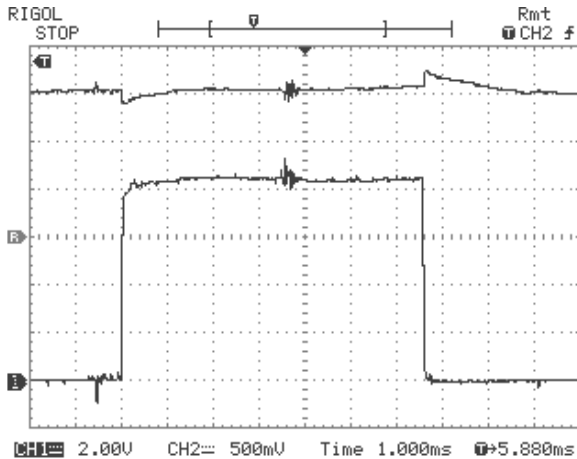

Figure 7: The waveforms for the voltage and current of the load resistance obtained practically.

VI. CONCLUSIONS

Implementation in digital technique of power voltage converters controllers at medium and high power has many advantages in terms of such a command performance, precise, with a high immunity to electromagnetic interference because all functional blocks are integrated into the same chip. Digital controllers still show the advantages of ease and flexibility of implementation and scalability. This implementation way allows carrying out high performance algorithms for power management and an increased possibility of interfacing the controlled converters with power supplied systems and communication with the external environment.

Acknowledgment

This work was supported by CNCSIS-UEFISCU, project number 48 PNII-RU, code 335/2010.

REFERENCES

- [1] Mohammad Kamil, "Switch Mode Power Supply (SMPS) Topologies (Part I)", AN1114, 2007 Microchip Technology Inc.
- [2] Antonio Bersani, "Switch Mode Power Supply (SMPS) Topologies (Part II)", AN1207, 2009 Microchip Technology Inc.
- [3] "SMPS AC/DC Reference Design User's Guide", DS70320B, 2008 Microchip Technology Inc.
- [4] "dsPIC33FJ06GS101/X02 and dsPIC33FJ16GSX02/X04 Data Sheet", DS70318D, © 2008 Microchip Technology Inc.
- [5] Viorel Popescu s.a., „Surse de alimentare in telecomunicatii”, Editura de Vest, Timisoara, 2002.
- [6] Robert Warren Erickson, Dragan Maksimovic, „Fundament of Power Electronics – Second edition”, Kluwer Academic Publishers, United States of America, 2001.
- [7] M. B. D'Amico, A. Oliva, E. E. Paolini y N. Guerin, "Bifurcation control of a buck converter in discontinuous conduction mode", *Proceedings of the 1st IFAC Conference on Analysis and Control of Chaotic Systems (CHAOS'06)*, pp. 399–404, Reims (Francia), 28 al 30 de junio de 2006.
- [8] Oliva, A.R., H. Chiacchiarini y G. Bortolotto "Developing of a state feedback controller for the synchronous buck converter", *Latin American Applied Research*, Volume 35, No 2, April 2005, pp. 83–88. ISSN: 0327-0793.

- [9] D'Amico, M. B., Guerin, N., Oliva, A.R., Paolini, E.E. "Dinámica de un convertidor buck con controlador PI digital", *Revista Iberoamericana de automática e informática industrial (RIAI)*, Vol 4, No 3, julio 2007, pp. 126–131. ISSN: 1697-7912;
- [10] Chierchie, F. Paolini, E.E. "Discrete-time modeling and control of a synchronous buck converter" *Argentine School of Micro-Nanoelectronics, Technology and Applications*, 2009. EAMTA 2009.1–2 October 2009, pp. 5-10. ISBN 978-1-4244-4835-7.
- [11] Lu Jiaying, Wu Xiaobo, "A Novel Piecewise Linear Slope Compensation Circuit in Peak Current Mode Control", *EDSSC 2007, Electron Devices and Solid-State Circuits, IEEE Trans. on*, pp. 929-932, Dec. 2007.
- [12] S. Sammanta, P. Patra, S. Mukhopadhyay, A. Patra, "Optimal slope compensation for step load in peak current controlled dc-dc buck converter", *Power Electronics and Motion Control Conference*, 2008. EPE-PEMC 2008. 13th, Sept. 2008, pp. 485-489;
- [13] Y. Li, X. Lai, F. Chen, B. Yuan, X. Jia, "An adaptive slope compensation circuit for buck DC-DC converter", *ASICON '07. 7th International Conference on ASIC*, Oct. 2007, pp. 608-611.
- [14] D. Maksimovic, R. Zane, R. W. Erickson, "Impact of Digital Control in Power Electronics", *IEEE International Symposium on Power Semiconductor Devices and ICs*, pp. 13-22, May 200.
- [15] T. Grote, H. Figge, N. Fröhleke, W. Beulen, F. Schafmeister, P. Ide, J. Böcker, „Semi-Digital Interleaved PFC Control with Optimized Light Load Efficiency“, *Applied Power Electronics Conference and Exposition, APEC 2009, Twenty-Fourth Annual IEEE*, pp. 1722-1727.
- [16] Octavian Adrian Botez, Mihai Lucanu si Cristian Aghion, „Study of digital technology implementation of peak current control method applied to synchronous buck converter”, *ISSCS International Symposium*, 01/07/2011, ISBN: 978-1-4577-0201-3, paginile 523-526.