

Digilent USB 2 Module Reference Manual

Revision: September 21, 2004



www.digilentinc.com

246 East Main | Pullman, WA 99163
(509) 334 6306 Voice and Fax

Overview

The Digilent USB 2 Module adds a USB 2.0 port to Digilent system boards. The module is based on the Cypress CY7C68013, and it can be used to configure system boards or to exchange data with a PC. Firmware in the Cypress chip works with Digilent's PC-based Adept software to coordinate JTAG programming and user data transfers. The user data port is modeled after the 14-signal "Enhanced Parallel Port" (EPP) protocol.

For JTAG programming, the Digilent Adept software tools can transfer .bit or .svf files directly to the Cypress chip, where the resident firmware then drives the JTAG chain as required. See the *Digilent Adept Reference Manual* for more information. Both the Adept software and reference manual are available for download from the Digilent website.

For user data transfers, Digilent provides a DLL, API, the required Windows drivers, and a VHDL reference design (for inclusion in the system board). The DLL, API, and drivers can be downloaded and installed as a part of the Digilent Adept software available at the Digilent website. The VHDL reference design is available as a separate download. See the *Digilent Port Communications Reference Manual*, the *Digilent Parallel Interface Model Reference Manual*, and the VHDL source file "dpimref.vhd" for more information).

The Digilent USB 2 Module is compatible with all newer Digilent system boards (including the S-3 Starter, Pegasus, D2SB, and D2FT boards). It can also be used with the older D2 and D2E for user data transfers (but not for programming – see the individual board documentation for more information).

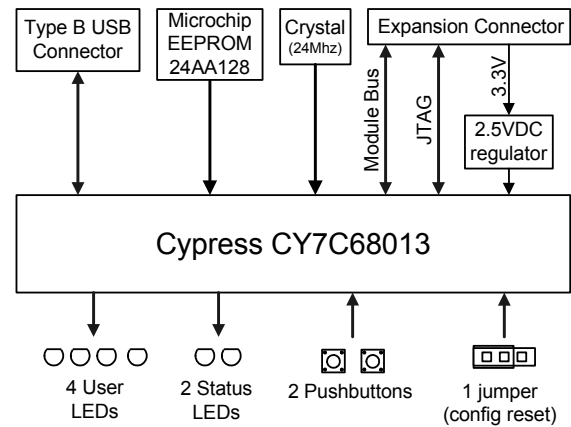

USB 2 Module Block Diagram

Cypress CY7C68013

The Cypress CY7C68013 provides an "all in one" USB 2 connectivity solution that includes the USB interface and an 8051-based processor. Digilent firmware running on the Cypress part supports a packet-transfer protocol that can be used for JTAG programming and user data transfers. Windows DLLs, APIs, and drivers that interact with the firmware can be freely downloaded from Digilent. These software modules can be used by user applications to transfer data between a system board and an attached PC.

The firmware in the Cypress chip can be modified using the Cypress EZ-USB Development kit available from Cypress. Digilent does not offer any independent method or user support for modifying the firmware.



Module Communications

The Digilent Adept Windows software has been created to manage communications with USB modules. The Adept software can identify a particular USB module using either a serial number or an ID string. A unique serial number and the default ID string “DModUsb” are programmed into the USB module during manufacturing (the serial number is also printed on a label affixed to the module). Digilent provides a “USB Administrator” tool as part of the Adept software that can be used to modify the 16-character ID string (see the *Digilent Adept Reference Manual* for more information).

USB modules can only be used for JTAG programming or user data transfers after they have been identified within the Adept software. Modules are identified by adding their serial number or ID string to a “Device Table” accessed through the “Communications Module” dialog box in Adept Suite (see the *Digilent Adept Reference Manual* for more information).

USB modules should generally be connected to the A1, B1, or C1 expansion connector of system boards for proper operation. They can be connected at other expansion connectors, but JTAG programming will not be available. In operation, it is recommended that the system board be turned off prior to connecting the module.

Application Software

Digilent provides a Software Development Kit that contains the necessary DLLs, APIs, and Windows drivers to allow users to create their own USB2 transport applications. In the Adept software suite, Digilent also provides two application programs called Export (for JTAG programming) and Transport (for user data transfers). See the *Digilent Software Development Kit Reference Manual* and *Digilent Adept Reference Manual* for more information on these applications.

User I/O

The USB 2 Module contains several I/O devices, including six status LEDs, 2 debounced pushbuttons and one 2-pin jumper.

Pushbuttons and Jumper

The USB2 Module has 2 pushbuttons and one 2-pin jumper that are not used by the Digilent Firmware loaded on the Cypress Chip. The user may configure the buttons and jumper as inputs with the Cypress EZ-USB Development Kit.

Status LEDs

- LED1: Indicates that the Digilent Firmware is loaded and ready.
- LED2: Indicates data activity on the USB2 Module.
- LED3-6: Not currently used. Can be configured as user outputs with the Cypress EZ-USB Development Kit.

Other Useful Information

The following items are all available for free download from the Digilent website.

Documents

- Digilent Adept Reference Manual
- Digilent Port Communications Reference Manual
- Digilent Parallel Interface Model Reference Manual
- Digilent JTAG Scan Reference Manual

Software

- Digilent Adept Suite
- Digilent Adept Software Developers Kit

Reference Designs

- VHDL source file “dpimref.vhd”



Pinout table

The table below provides the pin assignments for the expansion connector.

Pin #	Signal
1	TDI
2	TDO
3	TMS
4	TCK
5	INT
6	JTSEL
7	WAIT
8	RESET
9	/DSTB
10	WRITE
11	DB7
12	ASTB
13	DB5
14	DB6
15	DB3
16	DB4
17	DB1
18	DB2
19	
20	DB0
21	
22	
23	
24	
25	
26	
27	
28	
29	
30	
31	
32	
33	
34	
35	
36	
37	VDD33
38	
39	GND
40	