

TR-202

ADSL2/ADSL2plus Low-Power Mode Guidelines

Issue: 1
Issue Date: February 2010

Notice

The Broadband Forum is a non-profit corporation organized to create guidelines for broadband network system development and deployment. This Broadband Forum Technical Report has been approved by members of the Forum. This Broadband Forum Technical Report is not binding on the Broadband Forum, any of its members, or any developer or service provider. This Broadband Forum Technical Report is subject to change, but only with approval of members of the Forum. This Technical Report is copyrighted by the Broadband Forum, and all rights are reserved. Portions of this Technical Report may be copyrighted by Broadband Forum members.

This Broadband Forum Technical Report is provided AS IS, WITH ALL FAULTS. ANY PERSON HOLDING A COPYRIGHT IN THIS BROADBAND FORUM TECHNICAL REPORT, OR ANY PORTION THEREOF, DISCLAIMS TO THE FULLEST EXTENT PERMITTED BY LAW ANY REPRESENTATION OR WARRANTY, EXPRESS OR IMPLIED, INCLUDING, BUT NOT LIMITED TO, ANY WARRANTY:

- (A) OF ACCURACY, COMPLETENESS, MERCHANTABILITY, FITNESS FOR A PARTICULAR PURPOSE, NON-INFRINGEMENT, OR TITLE;
- (B) THAT THE CONTENTS OF THIS BROADBAND FORUM TECHNICAL REPORT ARE SUITABLE FOR ANY PURPOSE, EVEN IF THAT PURPOSE IS KNOWN TO THE COPYRIGHT HOLDER;
- (C) THAT THE IMPLEMENTATION OF THE CONTENTS OF THE TECHNICAL REPORT WILL NOT INFRINGE ANY THIRD PARTY PATENTS, COPYRIGHTS, TRADEMARKS OR OTHER RIGHTS.

By using this Broadband Forum Technical Report, users acknowledge that implementation may require licenses to patents. The Broadband Forum encourages but does not require its members to identify such patents. For a list of declarations made by Broadband Forum member companies, please see <http://www.broadband-forum.org>. No assurance is given that licenses to patents necessary to implement this Technical Report will be available for license at all or on reasonable and non-discriminatory terms.

ANY PERSON HOLDING A COPYRIGHT IN THIS BROADBAND FORUM TECHNICAL REPORT, OR ANY PORTION THEREOF, DISCLAIMS TO THE FULLEST EXTENT PERMITTED BY LAW (A) ANY LIABILITY (INCLUDING DIRECT, INDIRECT, SPECIAL, OR CONSEQUENTIAL DAMAGES UNDER ANY LEGAL THEORY) ARISING FROM OR RELATED TO THE USE OF OR RELIANCE UPON THIS TECHNICAL REPORT; AND (B) ANY OBLIGATION TO UPDATE OR CORRECT THIS TECHNICAL REPORT.

Broadband Forum Technical Reports may be copied, downloaded, stored on a server or otherwise re-distributed in their entirety only, and may not be modified without the advance written permission of the Broadband Forum.

The text of this notice must be included in all copies of this Broadband Forum Technical Report.

Issue History

Issue Number	Issue Date	Issue Editor	Changes
1	February 2010	L.D.Humphrey, BT	Original

Comments or questions about this Broadband Forum Technical Report should be directed to info@broadband-forum.org.

Editor: Les Humphrey BT

**Testing&Interoperability
WG Chair** Les Brown Lantiq

Vice Chairs Lincoln Lavoie UNH-IOL
Massimo Sorbara Ikanos

TABLE OF CONTENTS

EXECUTIVE SUMMARY	5
1 PURPOSE AND SCOPE.....	6
1.1 PURPOSE	6
1.2 SCOPE	6
1.3 ACKNOWLEDGEMENT	6
2 REFERENCES AND TERMINOLOGY.....	7
2.1 CONVENTIONS	7
2.2 REFERENCES	8
2.3 DEFINITIONS	8
2.4 ABBREVIATIONS	9
3 TECHNICAL REPORT IMPACT	10
3.1 ENERGY EFFICIENCY.....	10
3.2 IPV6.....	10
3.3 SECURITY.....	10
4 RECOMMENDED GUIDELINES FOR KEY PARAMETERS	11
5 OTHER RECOMMENDED GENERAL GUIDELINES.....	12
APPENDIX A: INTRODUCTION TO THE ADSL2 AND ADSL2PLUS POWER SAVING MODES 13	

List of Figures

Figure A-1 How L2-mode works.....	13
-----------------------------------	----

List of Tables

Table 4-1 Recommended values for L2 mode control parameters.....	11
Table A-1 Range of permitted values for L2 mode control parameters	14

Executive Summary

TR-202 provides a set of guidelines for the deployment of the power saving feature for the central office ATU with the L2 low power state defined in ITU-T Recommendation G.992.3 and G.992.5. Service providers in several countries have indicated that there is an opportunity to make significant savings in the electrical energy demand required to operate the network by enabling the ADSL2/ADSL2plus L2 mode.

If this mode is enabled care must be taken that parameter values are set in a way such that the risk of network instability is minimized, and the implementation guidelines herein should be used in deployment of ADSL low power saving mode.

1 Purpose and Scope

1.1 Purpose

The purpose of TR-202 is to provide practical guidelines for Operators and Service Providers for the use of the existing low-power operational modes embodied in ITU-T Recommendations for ADSL2 [2] and ADSL2plus [3] technology, while minimising the risk that some emerging high speed services (e.g. IPTV) and delay sensitive services (e.g. VOIP) could be adversely impacted by the use of the ADSL2/2plus L2 mode.

Furthermore, there is a need to use energy as efficiently as possible in order to minimize carbon footprint in a low-carbon economy. The use of low power mode(s) (e.g. L2) for ADSL2 and ADSL2plus is recognized as a key method of reducing the carbon footprint of the broadband ecosystem.

1.2 Scope

The scope of TR-202 is to provide guidelines for the use of the existing L2 mode embodied in ADSL2 [3] and ADSL2plus [3] technology. It is focussed on deployment in networks subject to metallic local loop unbundling or where there is a large installed base of legacy ADSL services.

This Technical Report is intended to inform the reader about the issues surrounding DSL power saving modes, and to guide those intending to adopt the use of such modes to implement them in a way that maximizes stability of their own and other operators' networks.

1.3 Acknowledgement

With the permission of NICC and Ofcom, this document uses and reproduces material taken from NICC Document ND1424 [5].

2 References and Terminology

2.1 Conventions

In this Technical Report, several words are used to signify the requirements of the specification. These words are always capitalized. More information can be found in RFC 2119 [1].

SHALL	This word, or the term “REQUIRED”, means that the definition is an absolute requirement of the specification.
SHALL NOT	This phrase means that the definition is an absolute prohibition of the specification.
SHOULD	This word, or the adjective “RECOMMENDED”, means that there may exist valid reasons in particular circumstances to ignore this item, but the full implications need to be understood and carefully weighed before choosing a different course.
SHOULD NOT	This phrase, or the phrase "NOT RECOMMENDED" means that there may exist valid reasons in particular circumstances when the particular behavior is acceptable or even useful, but the full implications should be understood and the case carefully weighed before implementing any behavior described with this label.
MAY	This word, or the adjective “OPTIONAL”, means that this item is one of an allowed set of alternatives. An implementation that does not include this option SHALL be prepared to inter-operate with another implementation that does include the option.

2.2 References

The following references are of relevance to this Technical Report. At the time of publication, the editions indicated were valid. All references are subject to revision; users of this Technical Report are therefore encouraged to investigate the possibility of applying the most recent edition of the references listed below.

A list of currently valid Broadband Forum Technical Reports is published at www.broadband-forum.org.

[1]	RFC 2119	<i>Key words for use in RFCs to Indicate Requirement Levels</i>	IETF	1997
[2]	G.992.3	<i>Asymmetric digital subscriber line transceivers 2 (ADSL2)</i>	ITU-T	04/2009
[3]	G.992.5	<i>Asymmetric Digital Subscriber Line (ADSL) transceivers – Extended bandwidth ADSL (ADSL2plus)</i>	ITU-T	01/2009
[4]	G.997.1	<i>Physical Layer Management for Digital Subscriber Line (DSL) Transceivers</i>	ITU-T	04/2009
[5]	ND1424	<i>Guidelines on DSL power saving models and non-stationary noise in metallic access networks)</i>	NICC	02/2008
[6]	EU CoC	<i>EU Code of Conduct on Energy Consumption of Broadband Communication Equipment</i>	European Commission	11/2008

2.3 Definitions

The following terminology is used throughout this Technical Report.

L0 State	Full power management state achieved after the initialization procedure has completed successfully (the ADSL link is fully functional)
L2 State	Low power management state (the ADSL link is active but a low power signal conveying background data is sent from the ATU-C to the ATU-R)
L3 State	Link state (Idle) at the start of the initialization procedure (there is no signal transmitting, the ATU may be powered or unpowered)

2.4 Abbreviations

This Technical Report uses the following abbreviations:

ANFP	Access Network Frequency Plan
ATU	ADSL Transceiver Unit
ATU-C	ATU at the central office end (i.e., network operator)
ATU-R	ATU at the remote terminal end (i.e., CP)
LLU	Local Loop Unbundling
L0-TIME	Minimum time between Exit from the L2 state and the next Entry into L2 state
L2-TIME	Minimum time between Entry into the L2 state and the first Power Trim in the L2 state and between two consecutive Power Trims in the L2 State
L2-ATPR	Maximum aggregate transmit power reduction that can be performed at transition of L0 to L2 state
L2-ATPRT	Total maximum aggregate transmit power reduction that can be performed in an L2 state
TR	Technical Report

3 Technical Report Impact

3.1 Energy Efficiency

This report provides a set of guidelines for the deployment of ADSL2/ADSL2plus L2 mode for power saving. Operators in several countries have indicated that there is a risk that some emerging high speed services (e.g. IPTV) could be adversely impacted by the use of the ADSL2/2plus L2 state (or mode) as currently standardised by the ITU-T Recommendations. However, there is an opportunity to make significant savings in the electrical energy demand required to operate the network by enabling the L2 state.

If the existing ADSL2/2plus L2 state is enabled by a Network Operator care must be taken that parameter values are set to minimise network harm, and the implementation guidelines herein should be used until improvements are made to the operational effectiveness of the L2 mode for ADSL2 or ADSL2plus.

According to [5] power savings of up to 2.9 GWh/year per million lines could be achieved by the judicious setting of the parameters that control the operation of the L2 state. Aggregated network power savings will be implementation dependent.

3.2 IPv6

TR-202 has no impact on IPv6.

3.3 Security

TR-202 has no impact on Security.

4 Recommended guidelines for key parameters

If L2 power saving mode is used in the access network it is recommended that the control parameters for it are set according to Table 4-1, and that any incumbent or LLU operator sharing the same metallic infrastructure use the same set of parameter values.

Table 4-1 Recommended values for L2 mode control parameters

L2 mode parameter	recommended value
L2-ATPR (dB)	1
L2-TIME (seconds)	≥ 127
L2-ATPRT (dB)	≤ 10
L0-TIME (seconds)	≥ 127

The above parameters are defined in [2] and [4] as well as in section 3 of this Working Text

NOTE: Application of these recommended values will result in a power saving of the order 75% [5] of that achievable using the most aggressive power saving parameters but with a much reduced impact on DSL performance (by virtue of the fact of the increased damping in the control system which minimises the fluctuating crosstalk).

NOTE: It may be appropriate also to set L2 “Minimum data rate in low power state” to a value lower than that necessary to support VoIP, so that at the start of a session the link immediately exits L2 state to ensure QoS and QoE for the duration of the call

5 Other recommended general guidelines

Where power saving is achieved by reducing the transmit signal level of an ADSL2 or ADSL2plus system, then the following recommendations hold:

1. That the maximum amount of signal reduction SHOULD be limited, preferably to no more than 10 dB, to limit the depth of crosstalk power fluctuation.
2. That any time-constants associated with the power reduction SHOULD be made lengthy (preferably many minutes or hours) to reduce the frequency of crosstalk fluctuations caused.

In particular these guidelines suggest that the ADSL2/ADSL2plus power saving state known as L3, which involves switching off the DSL line signal altogether, should be avoided as being far too disruptive to network stability.

Appendix A: Introduction to the ADSL2 and ADSL2plus power saving modes

ADSL2 transmission systems are standardized by the ITU-T recommendation G.992.3 [2] Section 9.5/G.992.3 specifies methods of reducing the transmit power of such systems that may be employed when the user data throughput is nil or low. Similarly ADSL2plus, standardized in ITU-T recommendation G992.5 [3], inherits the same functionality by reference to G992.3 [2].

In the description of these power saving modes L0 mode refers to the normal (full power operation), while L2 mode refers to the main mode of interest, a power saving mode that stops short of actually turning the transmit signal off altogether. The operation of this L2-mode is illustrated in Figure A-1.

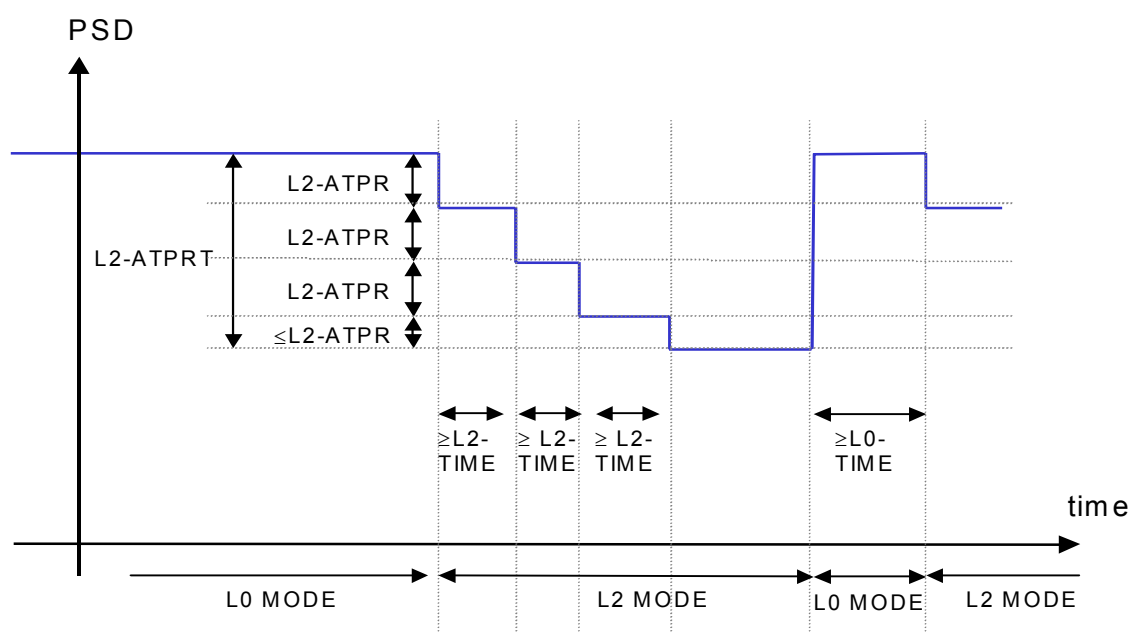

Figure A-1 How L2-mode works

In this figure it is assumed that initially the modem is operating in L0 mode and therefore transmitting at full power, when it is detected that little or no user data is being transmitted. As a result entry into L2 mode is enabled, resulting in an initial power reduction by L2-ATPR dB.

NOTE: The L2 power trim sent by the DSLAM may be rejected by the CPE due to an invalid or infeasible parameter. This can occur when there is no capacity left for further power reduction, or if further reduction of power might result in instability (negative noise margin on certain tones).

This level of power reduction SHALL be maintained for a period of at least L2-TIME seconds before further power reduction is permitted. Once this time has passed, if user data requirements still permit, a further reduction in power by L2-ATPR is enabled, and so on, provided that the

total power reduction does not exceed L2-ATPRT. If at any time user data throughput demands a higher transmit power level then immediate return to L0 mode is the only option. Once in L0 mode again, this mode SHALL be maintained for at least L0-TIME seconds before L2 mode can be invoked again.

The values of L2-ATPR, L2-TIME, L2-ATPRT and L0-TIME are all under control of the network operator and can be configured through the DSLAM or MSAN management system. The valid values for these parameters are defined in ITU-T recommendation G997.1 [4] and are reproduced in the table below.

Table A-1 Range of permitted values for L2 mode control parameters

L2 mode parameter	minimum permitted value	maximum permitted value
L2-ATPR (dB)	0	31
L2-TIME (seconds)	0	255
L2-ATPRT (dB)	0	31
L0-TIME (seconds)	0	255

All L2 mode power transitions represent a deviation from the stationarity of the transmitted signal. Having said this it is unlikely that the power reduction transitions of L2 mode will cause problems for systems operating on other access network pairs. Such transitions can only result in reductions of crosstalk levels being experienced by other systems, and therefore an improvement in their operating signal-to-noise ratios, and it is very unlikely that such improvements will disrupt their operation.

On the other hand the return to L0 mode is not so benign. It will inevitably result in a relative increase in crosstalk levels, and hence a relative decrease in the operating signal-to-noise ratio of systems operating on other pairs, which could very well have detrimental effects either in the form of data transmission errors or, in severe cases, collapse of the transmission system resulting in a retrain. Unfortunately, because of the way the protocol for return to L0 mode has been defined, the increase in transmit power is large and sudden, maximizing the potential for adverse effects on neighbouring systems. This is not because the problems of adverse crosstalk have not been considered at all in the design of L2 mode, rather that they have been relegated against the imperative that when the customer needs to transmit data he SHALL not be kept waiting. Despite this it is still possible to use L2 mode control parameters to mitigate the effects; for example smaller values of L2-ATPRT reduce the maximum size of power increase, and larger values of L2-TIME and L0-TIME will decrease the number of such events occurring.

The use, existence and definitions of L2 mode are spread throughout the ADSL2 standard, and their implementation (although not their use) is mandatory in the standard and even pre-dates the EU Code of Conduct [6]. The primary motivations for having the facility were the achievable power savings and its impact on the environment when there is low user traffic (e.g. during night time).

There is a lot of pressure on the industry to pack as many ports into as small a space as possible, and when this is done the thermal management and cooling may become an important issue. Since L2 only reduces the average power (over time) but not the instantaneous peak power consumption it cannot be used as a means for thermal management of single ports.

Each port still needs to be designed for the worst case power. Absolute power reduction per port is the domain of the annex-P compliant systems.

It is worth pointing out that the use of L2 mode does not conflict with the requirements of the national spectrum management guidelines (e.g. UK ANFP), since all that is happening is that power is being reduced below the maximum permitted. Since most spectrum management standards only invoke a cap on the maximum powers that may be transmitted, there is generally no conflict.

End of Broadband Forum Technical Report TR-202