

The PSK Modulation

- PSK is a modulation that modifies the phase of a carrier signal, at the beginning of the symbol period, with a value that depends on the multibit that has to be modulated
- it exhibits a good resilience to perturbations and distortions and has a rather good spectral efficiency factor, requiring a medium implementation complexity.

PSK signal constellations

- since the phase is not an absolute magnitude, requiring a reference, two types of phase modulation can be defined, acc. to the reference employed:
 - absolute phase modulation, Absolute PSK (APSK), where the phase-shifts of the modulated signal, occurring every symbol period, are referred to the phase of a reference signal, usually the unmodulated carrier signal.
 - differential phase modulation, Differential PSK (DPSK), where the phase-shifts of the modulated signal, occurring every symbol period, are referred to the phase of the phase of modulated carrier during the previous symbol period.
- figure 1 presents both variants of PSK on a cosine carrier, for the phase-shifts of $0, \pi/2, \pi$ and $3\pi/2$ “in advance”. The reference signal, for the APSK, is the non-modulated carrier.

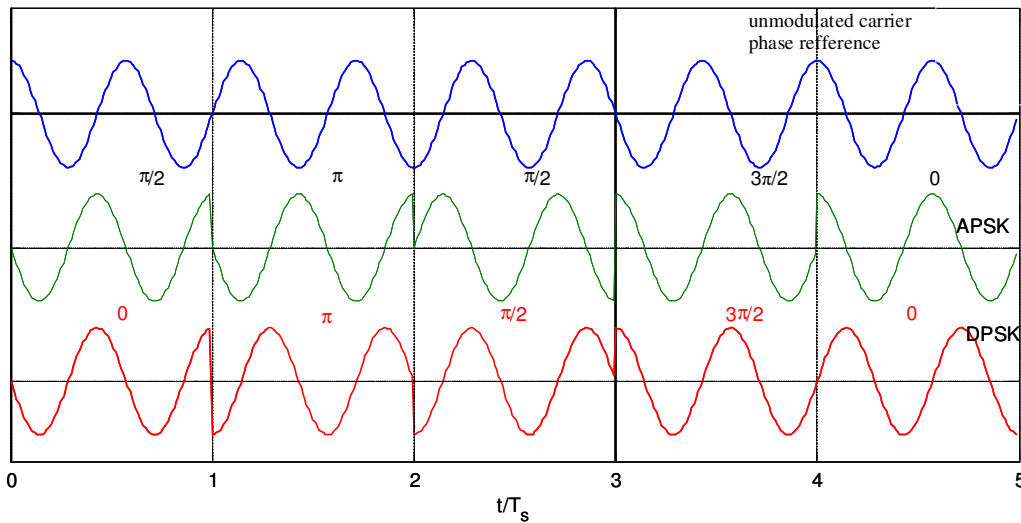

Figure 1. Types of PSK modulations

- the data bits are grouped into p -bit multibits; each multibit is modulated and transmitted within a symbol period, T_s .
- the relations between the symbol and bit periods and between the bit and signaling frequency are given by (1). Note that the signaling frequency is measured in Baud, i.e. 1 Baud = 1 symbol/sec:

$$T_s = p \cdot T_b; \quad f_b = p \cdot f_s; \quad (1)$$

- the number of phase-levels (states or vectors) of the modulated signal is: $N = 2^p$ (2)
- the signaling rate v_s , i.e. the number of variations/second of the modulated parameter(s) of the carrier signal, is measured in Bauds, symbols/second, and is numerically equal the frequency of the symbol-clock f_s ;
- the bit rate D , which is numerically equal to the bit-clock frequency f_b , is expressed by:

$$D = v_s \cdot p \text{ [symb/s} \cdot \text{bits/symb} = \text{bits/s}] \quad (3).$$

- the set of vectors that could be generated by PSK-modulating all possible p -bit multibits are represented in plane as signal constellations. Figure 2 shows the constellations corresponding to the PSK-modulations of table 1 with their variants, see the right-hand column.
- if the vectors are considered in polar coordinates, then all have an unitary radius, being identified by the differential phase-shift $\Delta\phi_k$, defined for each multibit, which is transmitted during a symbol period.
- for $p = 1$ and 2, two types of constellations are employed:
 - Type A, containing the $\Delta\phi_k = 0^\circ$ phase-shift
 - Type B, which do not contain the $\Delta\phi_k = 0^\circ$ phase-shift

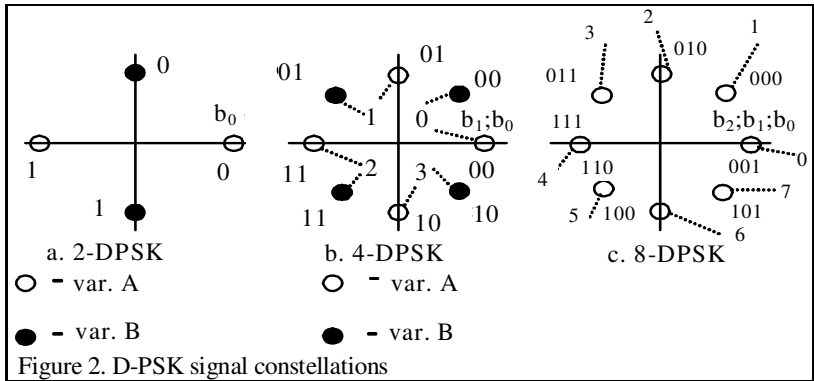

- the B-type constellations are generated by rotating the A constellations, in a trigonometrically positive sense, with half of the minimum phase-shift between their vectors
- in figure 2 each vector is denoted by a decimal label $k \in \{0, \dots, 7\}$.
- the constellation B8, which would involve a phase-rotation

of $45^\circ/2 = 22,5^\circ$ of the vectors from constellation A8, is not used; the motivation would be discussed in the section dealing with the symbol-clock synchronization.

Gray multibit-to-vector mapping

- the multibit-vector mapping is made according to the binary Gray code, ensuring a minimum Hamming distance of 1 bit between adjacent vectors.
- the maximum Hamming distance occurs between vectors separated by π , for both the 4-vector and 8-vector constellations.
- as shown in the PAM lecture, the Gray-mapping is employed to decrease the bit error probability, for a given symbol error probability. This property is proven for the PSK in the example below
- denote in constellation A4, the error-probability of vector 0 into vectors 1 or 3 by p_1 , and of vector 0 into vector 2 by p_2 ; then $p_1 > p_2$, because $d(0,3) = d(0,1) < d(0,2)$.
- For a Gray-mapping ($0 \leftrightarrow 00$; $1 \leftrightarrow 01$; $2 \leftrightarrow 11$; $3 \leftrightarrow 10$) the bit-error probability is expressed by (4).a

$$P_{bG} = 2 \cdot p_1 \cdot 1 + p_2 \cdot 2; \text{ a.} \quad P_{bn} = p_1 \cdot 1 + p_1 \cdot 2 + p_2 \cdot 1 = p_1 \cdot 3 + p_2 \cdot 1; \text{ b} \quad (4)$$

- for a mapping according to the natural binary code ($0 \leftrightarrow 00$; $1 \leftrightarrow 01$; $2 \leftrightarrow 10$; $3 \leftrightarrow 11$), the probabilities p_1 and p_2 have the same values as for the Gray-mapping. The bit-error probability is expressed by (4).b.
- comparing the bit-error probabilities ensured by the two mapping rules for the same symbol-error probability, we get:

$$P_{bG} - P_{bn} = p_2 - p_1 < 0 \rightarrow P_{bG} < P_{bn}; \quad (5)$$

- a similar reasoning was applied to PAM and may be applied to constellation A8, as well.

Expression of the PSK modulated signal

- the PSK modulated signal is expressed by (5); $u_T(t-nT_s)$ represents a rectangular impulse with unitary-amplitude and duration T_s , which indicates that the phase of the carrier $A \cos \omega_c t$ is modified with $\Delta \phi_n$ only during the n -th symbol-period.

$$s_{PSK}(t) = A \cdot \sum_{k=-\infty}^{\infty} u_T(t-kT_s) \cos(\omega_c t + \Delta \Phi_k); \quad (6)$$

- the modulated PSK signal is a succession of modulated signals during a symbol period; the phase-shifts of each symbol period do not interfere with one another.
- the phase reference that is used to compute the phase-shift $\Delta \phi_k$ indicates the type of modulation: absolute or differential.
- APSK is not employed in practice because the demodulation requires the separate phase-reference,.
- DPSK is used, because the phase-reference is the carrier's phase during the previous symbol period.

Spectral distribution of the QPSK signal

- the power spectral distribution of the all PSK constellations depends on the symbol frequency and on the type of the carrier signal, i.e. harmonic (cosine or sine) or rectangular
- a. when the carrier signal is a harmonic signal (having only one spectral component), the spectral distribution of the PSK signal is expressed by (7) for the non-filtered modulating levels, see (6).
- the spectrum, approximately represented in figure 3, exhibits a central lobe ($k = 0$), with a bandwidth equaling $2 \cdot f_s$ and maximum value S_{M0} , around the carrier frequency and side lobes with maxima S_{Mk} occurring at the f_M frequencies, given by (8). These spectral lobes are generated by $u_T(t-kT_s)$.

$$u_T(f) = \frac{1}{f_s} \frac{\sin \frac{\pi f}{f_s}}{\frac{\pi f}{f_s}}; \Rightarrow S_n(f) = \frac{A^2}{f_s} \cdot \left(\frac{\sin \frac{\pi(f-f_c)}{f_s}}{\frac{\pi(f-f_c)}{f_s}} \right)^2 \frac{V^2}{Hz}; \quad (7)$$

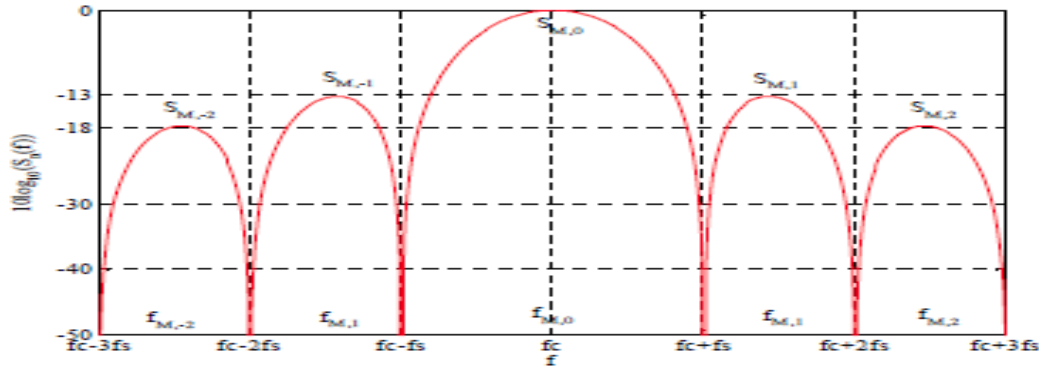

Figure 3 Power spectral distribution of the QPSK signal – non-filtered and RRC filtered

$$\begin{aligned} f_m &= f_c +/ - kf_s \quad k \neq 0; & f_M &= f_c +/ - (kf_s + f_s/2) \quad k \neq 0; \\ S_{M0} &= A^2/f_s; & S_{Mk} &= S_{M0} \cdot 4/[(2k+1)\pi]^2; \end{aligned} \quad (8)$$

- the amplitudes of the side lobes decrease rather slowly with the increase of their index.
- this is a disadvantage in transmission chains including non-linear high-frequency amplifiers
- Fig. 4 presents the filtered and non-filtered power spectra of a PSK signal, for $f_s = 0.33$ kHz, $\alpha = 0.5$.

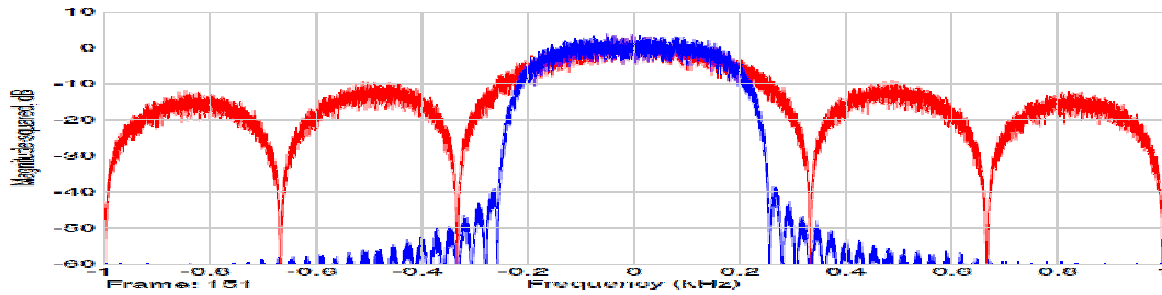
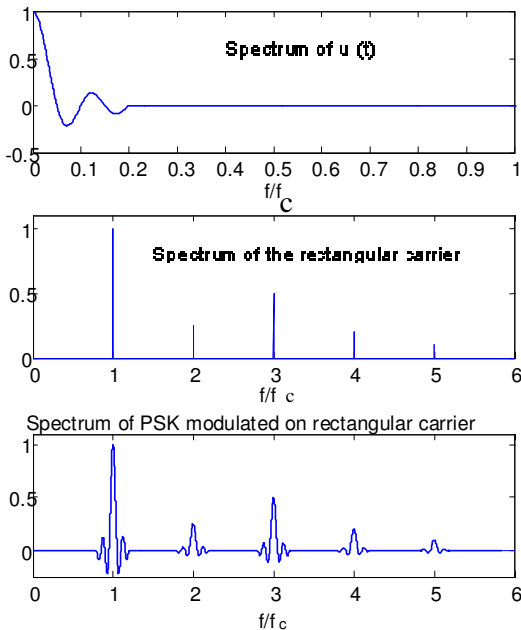

Figure 4 Power spectra of non-filtered and RRC-filtered PSK signals - snapshot



- **b.** If the carrier signal is rectangular, as for the direct digital PSK modulators, the spectrum of the modulating signal is translated around the harmonics of the carrier signal $k \cdot f_c$, see (9)

$$u_T(f - f_c) = T_s \sum_{k=1} A_k \frac{\sin \frac{\pi(f - kf_c)}{f_s}}{\frac{\pi(f - kf_c)}{f_s}} \quad (9)$$

- for a harmonic carrier signal, the sum in (9) contains only one term, $k = 1$, see fig.3 and (7)
- figure 5 presents power spectra of the non-filtered modulating signal, $u_T(t - mT_s)$, rectangular carrier signal and PSK modulated signal

Fig.5 Spectrum of PSK modulated on a rectangular carrier

Filtering the PSK modulated signals

- the considerations above show that the modulated signal has to be filtered, so that it would match the channel bandwidth.

- due to the frequency-band limitation, the filtered signal “expands” in time generating the ISI.

- to remove (or at least decrease) the ISI in the probing moments, the signal has to be filtered with a RC characteristic with a roll-off factor α , see the lecture on Filtering the Data Signals).

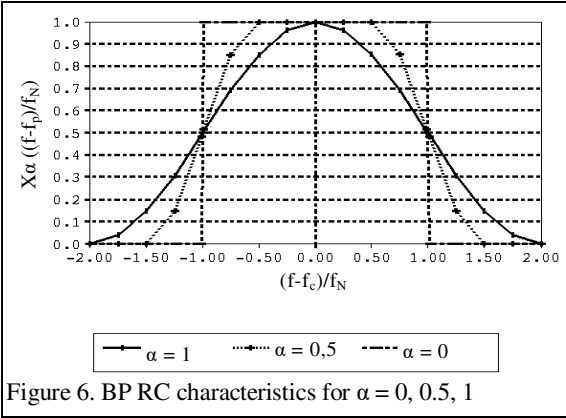

Figure 6. BP RC characteristics for $\alpha = 0, 0.5, 1$

- for better performances in the presence of the Gaussian noise, the filtering characteristic has to be equally-split between transmitter and receiver, as shown there This involves filtering with a RRC characteristic both in the transmitter and receiver.

Basically, the RRC filtering may be implemented in two variants:

- a band-pass filtering placed after the PSK modulator; this option is used by the direct digital PSK modulators which generate the PSK signal on a rectangular carrier signal, as will be shown in the

chapter dedicated to the PSK modulation and in Annex 1. The BP-RRC filtering characteristic is defined by (10) and represented in fig.6:

$$N_E(\omega - \omega_c) = N_R(\omega - \omega_c) = N(\omega - \omega_c)^{\frac{1}{2}} = \begin{cases} 1; & \omega \in [\omega_c - \omega_N(1 - \alpha), \omega_c + \omega_N(1 - \alpha)]; \\ \cos\left(\frac{\pi(\omega - \omega_c)}{4\omega_N\alpha} - \frac{\pi(1 - \alpha)}{4\alpha}\right); & \omega \in A; \end{cases} \quad (10)$$

$$A = [\omega_c - \omega_N(1 + \alpha), \omega_c - \omega_N(1 - \alpha)] \cup [\omega_c + \omega_N(1 - \alpha), \omega_c + \omega_N(1 + \alpha)];$$

- a low-pass filtering applied to the modulating signal; this approach is used if the PSK signal is generated using the QAM technique, see the chapter on PSK modulation This method is preferred in most applications. The LP-RRC filtering characteristic is defined by equation (7) in the lecture on Filtering the Data Signals and can be obtained by making $\omega_c = 0$ in (10) above.

Effects of filtering the PSK-modulated signals

- the goals of filtering the modulated signal with a global RC characteristic are:

- limitation of the frequency band occupied by the modulated signal;
- removal of ISI in the probing moments

- if the modulating moments are at the beginning of the symbol period, negative edge of the symbol clock f_s , then, due to the $\tau_g(f)$ characteristic of the filter, the probing moments are placed in the middle of the symbol periods, i.e. positive edge of the symbol clock f_s , see the data filtering.

- to analyze the effects of filtering upon the momentary phase and frequency and upon the envelope of the modulated signal, we consider that the signal phase suffers a shift from the phase of the previous symbol, denoted by 0° , to $\Delta\Phi_k$. Denoting by $\Phi(t)$ the phase-shift inserted by the modulator, the modulated signal would be expressed by:

$$s(t) = A\cos(\omega_p t + \Phi(t)); \quad \Phi(t) = \Delta\Phi_k u_T(t + T/2 - kT) = \Delta\Phi_k; \quad t \in [kT - T/2; kT + T/2]; \quad (11)$$

- theory shows that after the filtering, the momentary phase of the modulated signal $\Phi(t)$ has a continuous variation described by (11), where $x(t)$ denotes the impulse-response of the RC filter, represented in figure 5 for $\alpha = 1$. In figure 5, the time-reference moment is the probing moment, $t = 0$, therefore the modulating moments occur at odd multiples of $T/2$.

$$\frac{\phi(t)}{\Delta\Phi_k} = \frac{1}{\Delta\Phi_k} \cdot \arctan \frac{\sin \Delta\Phi_k}{\frac{1}{x(t)} - 2\sin^2 \frac{\Delta\Phi_k}{2}}; \quad (12)$$

- fig. 7 presents the variation of the momentary phase for $\Delta\Phi_k = k \cdot 2\pi/8$, $k \in \{1, \dots, 4\}$.

- it shows that the momentary phase has very small (close to zero) values in all probing moments, $t = k \cdot T_s$, except for the main probing moment $t = 0$, (third axis in fig. 7).

- in the main probing moment phase $\Phi(t)$ reaches approximately the nominal value $\Delta\Phi_k$ of the current symbol. This shows that ISI has been significantly decreased in the phase domain, i.e. in every probing moment and only then, the momentary phase has the nominal value of the phase-shift of that symbol and is very slightly affected by the "time-expansion" of the phase-shifts of other symbol-periods.

- note also that the momentary phase $\Phi(t)$ reaches half of its nominal value at $t = \pm T/2$.

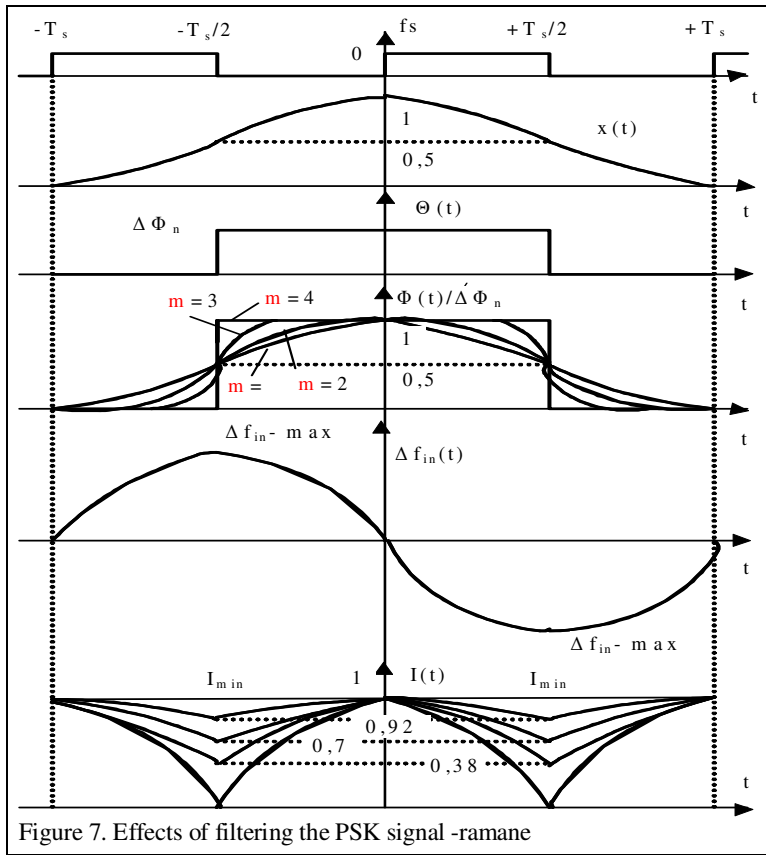

Figure 7. Effects of filtering the PSK signal -ramane

frequency around the carrier frequency, is shown on the 5-th axis of fig. 7.

- the deviation of the momentary frequency has maxima at approximately $t = \pm T/2$. The values of these maxima depend of the value of phase-shift $\Delta\Phi_k = m \cdot \pi/4$, and can be computed using (14).

$$\Delta f_{inmax} = m \cdot f_s/8; \quad m = k, \text{ for } k = 0, \dots, 4; \quad m = k - 8, \text{ for } k = 5, \dots, 7; \quad (14)$$

- the envelope $I(t)$ of the filtered modulated signal is shown to be no longer constant; it varies in time according to (15).a, see the 6-th axis of figure 5.

$$I(t) = A \cdot \sqrt{1 - 4 \sin^2 \frac{\Delta\Phi_n}{2} \cdot x(t)[1 - x(t)]}; \quad \text{a.} \quad I_{min} = A \left| \cos \frac{\Delta\Phi_n}{2} \right|; \quad \text{b.} \quad (15)$$

- (15).a shows that the envelope of the filtered signal has a maximum at the probing moment $t=0$ and minima at $t = \pm T/2$. The values of the minima are expressed by (15).b and depend of the phase-shift value. For $\Delta\Phi_k = m \cdot 2\pi/8$, $m \in \{0, \dots, 7\}$ these minima have five possible values, 1, 0.92, 0.707, 0.38, 0, which are represented in figure 7

- note that for $\Delta\Phi_k = 0^\circ$, the variations of momentary phase, frequency deviation and of the envelope are zero. This is a major disadvantage of the A type constellations.

- summarizing, the goals of filtering the (D)PSK signals are:

- decrease of the occupied frequency BW, so that it would match the channel BW;
- removal of ISI in the probing moments.

- the consequences of filtering the (D)PSK signals with an RC characteristic are:

- the probing moment is displaced with half of symbol-period, from the modulation moment;
- a continuous variation of the momentary phase, with maxima, approximately equaling the nominal phase-shift, at the probing instants;
- continuous variation of momentary frequency, with maximum deviation from the carrier frequency occurring at $t=\pm T/2$; the maximum values of the frequency deviation depend of the phase-shift values.
- the occurrence of a “parasitic” amplitude modulation, i.e. the envelope, which has maxima at the probing moments and minima at approximately the modulating moments $t = \pm T/2$. The minima’s values depend on the values of the phase-shifts.

Generation of the DPSK signals

- the DPSK signals can be generated by direct digital methods or by employing the QAM technique

- for $\Delta\Phi_k = \pi$, the phase variation is almost rectangular, and for $\Delta\Phi_k = 0$, the phase variation is zero.

- at $t = \pm T/2$, the momentary phase has inflexion points.

- the variation of the momentary frequency $f_{in}(t)$ around f_c , after the filtering, can be derived from the $\Phi(t)$ variation law by:

$$\Delta f_{in}(t) = \frac{1}{2\pi} \cdot \frac{d\Phi(t)}{dt} \quad (13)$$

- the $\Delta f_{in}(t)$ can be derived easier by performing the graphical derivative of $\Phi(t)$. The inflexion points would become extreme points for the derivate function; the monotony of the derivate function can be derived from the concavity/convexity of $\Phi(t)$, and the sign of the derivate function, from the monotony of the $\Phi(t)$. The resulted curve, which approximately described the variation of the momentary

DPSK digital modulators

- two digital modulators which produce directly the APSK and DPSK signals for all constellations are presented in Annex 1; **they are not included in the examination topics**

DPSK modulation-demodulation employing the QAM modulation (technique)

- the expression of the (D)PSK signal over one (k-th) symbol-period is given by (16), where Φ_k denotes the absolute phase of the carrier during the k-th symbol period:

$$s_{PSK} = A \cos(\omega_p t + \Phi_k) u_T(t - kT); \quad (16)$$

- by expanding (16) we get (17), which represents a QAM signal in which the two modulating signals are no longer independent signals; they fulfill condition (18).

$$s_{PSK} = A \cdot \cos \Phi_k \cdot u_T(t - kT) \cdot \cos \omega_p t - A \cdot \sin \Phi_k \cdot u_T(t - kT) \cdot \sin \omega_p t = I(kT) \cdot A \cos \omega_p t - Q(kT) \cdot A \sin \omega_p t; \quad (17)$$

$$I(kT) = I_k = \cos \Phi_k \cdot u_T(t - kT); Q(kT) = Q_k = \sin \Phi_k \cdot u_T(t - kT); \text{ with } I_k^2 + Q_k^2 = 1 \cdot u_T(t - kT_s)$$

- if the modulating symbols are written as (18).a then the PSK signal can be written as (18).b :

$$m_k = I_k + jQ_k = A_k \cdot e^{j\Phi_k}; \text{ a.} \quad (18)$$

$$s_{PSK}(t) = \text{Re}\{(I_k + jQ_k) \cdot (\cos \omega_c t + j \sin \omega_c t)\} = \text{Re}\{A_k \cdot e^{j(\omega_c t + \Phi_k)}\}; \text{ b.}$$

DPSK modulation generated by the QAM technique

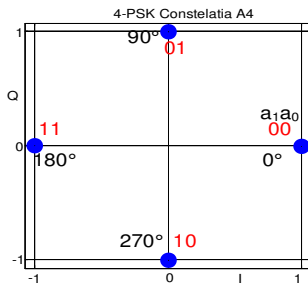

- as an example we present the generation of the A4 constellation, figure 8. Table 1 shows the phase-shifts $\Delta\Phi_k$, the values of the modulating levels (I_k , Q_k), the input dibit-data $a_1 a_0$ and of the dibit after the Gray-natural conversion (CGN), $b_1 b_0$, which is performed according to:

$$b_0 = a_0 \oplus a_1; \quad b_1 = a_1; \quad (19)$$

Figure 8. The A4 signal constellation

- this method generates an absolute-phase modulation, since the modulated carrier's phase-shifts are referred to the phase of the non-modulated carrier.

Most often the literature denotes by QPSK the 4- APSK (variant A or B).

$a_1 a_0$	$b_1 b_0$	I_k	Q_k	$\Delta\Phi_k$
00	00	+1	0	0°
01	01	0	+1	90°
11	10	-1	0	180°
10	11	-0	-1	270°

Table 1. Signal values in the main points of the DPSK-A4 encoder for $c_1^{k-1} c_0^{k-1} = 00$

- to transform this modulation into a DPSK one, the absolute phase of the modulated carrier should be modified according to (20).

$$\Phi_k = (\Phi_{k-1} + \Delta\Phi_k)_{\text{mod } 360^\circ} \quad (20)$$

- because all $\Delta\Phi_k$ are multiples of 90° , the absolute phase will be a multiple of 90° and (20) may be written as:

$$\Phi_k = N_k \cdot 90^\circ \Rightarrow \Phi_k = (N_{k-1} \cdot 90^\circ + \Delta N_k \cdot 90^\circ)_{\text{mod } 360^\circ} \Leftrightarrow N_k = (N_{k-1} + \Delta N_k)_{\text{mod } 4} \quad (21)$$

- but the numbers N_k and ΔN_k are binary represented by the dibits $c_1^k c_0^k$ and $b_1^k b_0^k$; then (21) may be written as:

$$(b_1^k b_0^k + c_1^{k-1} c_0^{k-1})_{\text{mod } 4} = c_1^k c_0^k; \quad (22)$$

- (21) and (22) show that to obtain a DPSK, the dibit that is delivered to the circuit that computes the I_k and Q_k levels is obtained by differentially precoding the modulating data-dibit, after the GN conversion.

- the block diagram of the DPSK modulator implemented by the QAM technique, is shown in fig. 9.

- the I_k and Q_k levels can be obtained by two methods:

- by reading the I_k and Q_k values from a table, in terms of the current data dibit and previous encoded dibit, when the GN conversion and the differential encoding are included;

- by using a D/A converter and a circuit that computes the bits which control the D/A converter

- on a DSP implementation, the CGN and differential precoding are performed off-line; the I_k and Q_k levels are read from a table, in terms of current data and previous encoded-data dibits; this block is called encoder or mapper.

- to limit the bandwidth of the modulating signal and ensure ISI= 0 in the probing moments, the I_k and Q_k signals would be LP filtered (FFE blocks) with a RRC characteristic with a roll-off factor of α

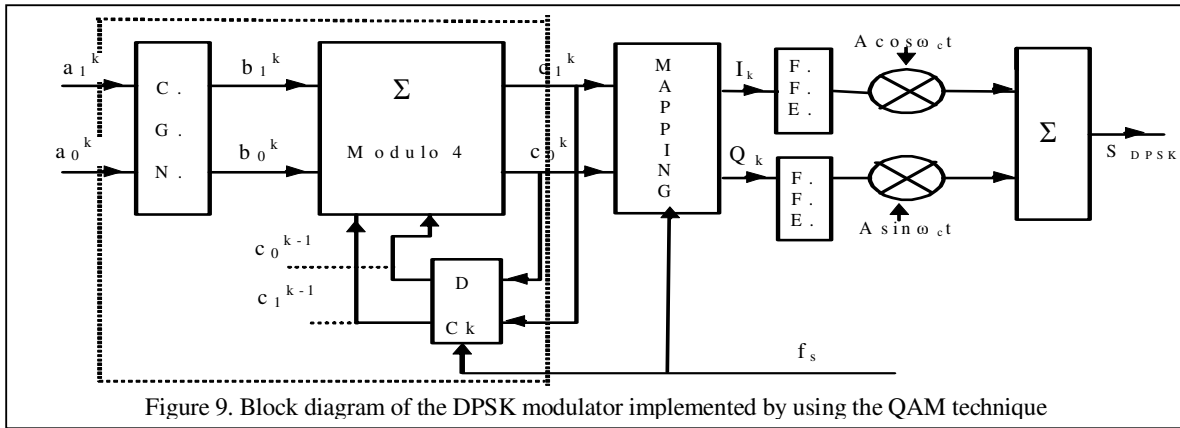

Figure 9. Block diagram of the DPSK modulator implemented by using the QAM technique

- after the filtering we get the continuous modulating signals $I(t)$ and $Q(t)$.
- the expression of the transmitted modulated signal is:

$$s_{\text{DPSK}}(t) = I(t) \cos \omega_c t - Q(t) \sin \omega_c t = \quad (23)$$

$$I(t) = A \cdot \cos \Phi_k \cdot u_T(t - kT) \text{ after filter; } Q(t) = A \cdot \sin \Phi_k \cdot u_T(t - kT) \text{ after filter;}$$

- the LP-RRC filtering is implemented using a FIR structure, in which only one sample of the I_k and Q_k levels should be inserted in every symbol-period; the rest of the samples of that symbol period would equal zero, see DSP lectures and Data Transmissions lectures
- when implemented on a signal processor, the symbol period is divided into N sampling periods. The encoding, multiplication and addition operations are executed for each sample. A BP filter should be added at the modulator's output, to suppress quantization noise.
- the samples of the carrier signals would be stored in a table, N values per symbol period; the digital generation of the carrier signals should ensure a small THD factor.
- this method can be applied if the frequency of the carrier allows its implementation on a processor;
- for carrier signals with greater frequencies, the digitally filtered signals ($I(t)$ and $Q(t)$) are multiplied to the carrier signal by analogue multipliers and the summation is performed by an analogue adder.

Generating other DPSK constellations with the QAM technique

Constellations A2 and B2

- since these constellations involve phase-shifts of $\Delta\Phi_n=0^\circ$ or 180° and, respectively, $\Delta\Phi_n=90^\circ$ or $\Delta\Phi_n=270^\circ$, which define the vectors of the two constellations, the QAM- expression of the 2- DPSK signals are:

$$s_{\text{SPSK-A2}}(t) = \pm A \sum_{n=-\infty}^{\infty} \cos(\omega_p t) u_T(t - nT); \quad s_{\text{SPSK-B2}}(t) = \pm A \sum_{n=-\infty}^{\infty} \sin(\omega_p t) u_T(t - nT); \quad (24)$$

- the values of the modulating levels I_k and Q_k of the A2 and B2 are presented in table 2.

Constellation	Bit	I_k	Q_k
A2	0	+1	0
A2	1	-1	0
B2	0	0	+1
B2	1	0	-1

Table 2. Values of I_k and Q_k for constellations A2 and B2

- the modulation and its block diagram remain the same as the ones described above for QPSK, except for the differential precoding (at the transmitter) - decoding (at the receiver) that are performed as mod 2 operations on one bit.

Constellation B4

- QAM generation of B4 requires a modulo-8 differential precoding-decoding on 3 bits.
- the $b_1 b_0$ dibit obtained after the Gray-natural conversion is transformed in the $b_2^* b_1^* b_0^*$ tritbit:

$$b_2^* = b_1; \quad b_1^* = b_0; \quad b_0^* = "1"; \quad (25)$$

- setting the bit $b_0^* = "1"$ is equivalent to the 45° rotation imposed by this constellation.
- then, after the differential precoding, (22) applied for three bits as mod8, which generates the tritbit $c_0 c_1 c_2$, the value of the absolute phase would alternatively (in successive symbol periods) equal an odd and then even multiple of 45° .
- the modulating levels would take alternatively values from the sets $A = \{-1, 0, 1\}$ sau $B = \{-\sqrt{2}/2, +\sqrt{2}/2\}$, the set being chosen by the value of the c_0 bit, i.e. $c_0 = 0 \leftrightarrow$ set A, $c_0 = 1 \leftrightarrow$ set B; the pair of coordinates is then chosen by the bits $c_1 c_2$ from the selected set

- the $c_2c_1c_0$ tritbit is employed to select the modulating levels I_k and Q_k as shown in table 3 -see notes

Dibit $c_2c_1c_0 \rightarrow$	00(1/0)	01(1/0)	10(1/0)	11(1/0)
I_k	$+\sqrt{2}/2/0$	$-\sqrt{2}/2/-1$	$-\sqrt{2}/2/0$	$+\sqrt{2}/2/1$
Q_k	$+\sqrt{2}/2/1$	$+\sqrt{2}/2/0$	$-\sqrt{2}/2/-1$	$-\sqrt{2}/2/0$

Table 3. Values of the I_k and Q_k levels for constellation B4

- the rest of the operations required by the QAM-modulation-demodulation of B4 are similar to QPSK,

but the differential decoding should be a modulo 8 one

- note that after the demapping and differential decoding only the two most significant bits are employed in the final processing, because the differential phase shifts are multiples of $\pi/2$.

Constellation A8

- the QAM modulation-demodulation of the A8 are implemented similarly as the ones of A4, with the following differences:

- the values of the I_k and Q_k levels, in terms of the data tritbit $c_2c_1c_0$, are the ones of table 4

$c_2c_1c_0 \rightarrow$	000	001	010	011	100	101	110	111
I_k	$+\sqrt{2}/2$	+1	$-\sqrt{2}/2$	0	$-\sqrt{2}/2$	-1	$+\sqrt{2}/2$	0
Q_k	$+\sqrt{2}/2$	0	$+\sqrt{2}/2$	+1	$-\sqrt{2}/2$	0	$-\sqrt{2}/2$	-1

Table 4. Values of the I_k and Q_k levels for constellation A8.

- the differential precoding-decoding should be made modulo-8 on the three bits.

- **Annex 2** presents the block diagram of the DPSK transmitters that use the direct digital method to generate the modulated signal on a rectangular carrier and perform a BP-RRC filtering on a intermediate frequency f_i followed by a frequency translation on the channel carrier frequency- **it is not included in the examination topics**

Considerations Regarding the Implementation of the RC filtering of the (D)PSK signal -individual study - required for examination

- the RRC characteristic can be implemented either with analog or digital methods.
- the analog implementation provide acceptable (not good !) accuracy only for roll-off factor $\alpha > 0.75$.
- to ensure high accuracy and smaller roll-off factors, the RCC characteristic should be implemented digitally using a FIR filtering structure. For a brief presentation of this approach, see the Annex of the lecture on Filtering the Data Signals. This topic will be dealt with in the laboratory classes of the data Transmissions course in the IVth year.
- the RRC characteristic could be implemented either as band-pass filters, centered on the intermediate or channel frequency, or as low-pass filters, by filtering the modulating I_k and Q_k signals in base-band.
- the BP-RRC approach should be used for the transmitters that direct digital (D)PSK modulators, as the ones described in Annex 1 of this material. Their position in the transmitter is shown in Annex 2.
- the transmitters that implement the (D)PSK modulation using the QAM approach, as described above, could use either the BP or LP variants of the RRC filtering. Still, almost all implementations use the LP variant, by LP filtering the I_k and Q_k modulating signals, as also shown above.

Considerations Regarding the Frequency Translation of DPSK signals

- individual study- required for the examination

- the frequency translation from an intermediate-carrier frequency f_i to the channel-carrier frequency f_c or the other way around, can be accomplished by multiplying the signal to a translation signal of frequency f_i followed by a BP or LP filtering which would select the desired frequency band and attenuate the undesired spectral components resulted from multiplication.
- the multiplication can be made by using a multiplier or a chopper, see the LM and FM lectures
- the considerations below are made for the case when $f_c > f_i$, which is met in almost all practical applications.
- as shown by equation (52) at the end of the FM lecture, which is repeated here for convenience, if the $f_i > f_c$, the sign of the additional phase inserted by the modulating signal $\Phi(t)$ is changed, while for $f_i < f_c$ it is not changed.

$$|\omega_c - \omega_i| = \omega_i \Rightarrow \begin{cases} \omega_c > \omega_i \Rightarrow \omega_i = \omega_c - \omega_i & \text{and } s_i(t) = k_f V' \cos(\omega_i t + \Phi(t)); & a. \\ \omega_c < \omega_i \Rightarrow \omega_i = \omega_c + \omega_i & \text{and } s_i(t) = k_f V' \cos(\omega_i t - \Phi(t)); & b. \end{cases} \quad (26)$$

- this conclusion shown there for the downwards translation, also holds for the upwards $f_i \rightarrow f_c$ translation.

- the sign change that occurs for $f_i > f_i$, (case b.) should be compensated in the modulator
- due to the changed sign of the phase-shift, the resulted phase-shift would correspond to a data multibit which equals the modulo (2^n) complement of the modulated data multibit (both in binary-natural representation) , for all constellations except for 2-PSK variant A. This systematic error should be compensated in the transmitter, after the G-N converter, by delivering at the modulator's input the complement modulo (2^n) of the multibit that has to be transmitted.
- the case when $f_c < f_i$ is met only for transmissions over the telephone channel, in the so called "dial-up" modems. For this situation similar results are obtained if we exchange f_i and f_c with each other.

Annex I- not required for examination

APSK and DPSK direct digital modulators built with an arithmetic adder and a counter - AAC

- due to the finite number of phase-shifts required and to the time-discreet character of the modulation, the digital methods ensure a higher accuracy and a better stability.
- the DPSK can be obtained both by DPSK modulators and by APSK modulators, preceded by a differential encoding of data multibit.
- the digital modulators will employ a serial-parallel converter, to build the multibits. This converter would acquire serially the input bits, using the bit-clock f_b , and the multibits will be read by the modulator using the symbol-clock f_s .
- then, the digital modulators would perform the Gray-binary natural conversion, CGN; the input multibit is looked-upon as Gray-coded combinations (to decrease the bit-error probability) and then they are converted into natural-binary combinations to match the modulator (as will be described later)
- *the bit-mapping may lead, sometimes, to a significant decrease of the bit-error probability, for the same symbol-error probability (the same SNR), still using the same implementation complexity.*
- the conversion between Gray and natural-binary codes is performed according to (6), g_i indicating the bits of the Gray-coded combination.

$$a_0 = g_0 \oplus g_1 \oplus g_2; \quad a_1 = g_1 \oplus g_2; \quad a_2 = g_2; \quad g_0 = a_0 \oplus a_1; \quad g_1 = a_1 \oplus a_2; \quad g_2 = a_2; \quad (A.1.1)$$

- the A8 constellation requires a modified (completed!) conversion rule, because the standard employs a different mapping rule, see fig. 2.c.

Homework: establish how relations (A.1.1) should be modified to accomplish the GNC for A8

- for a p-bit multibit, the modulator is implemented using a p-bit arithmetic adder a p-stage counter; it is

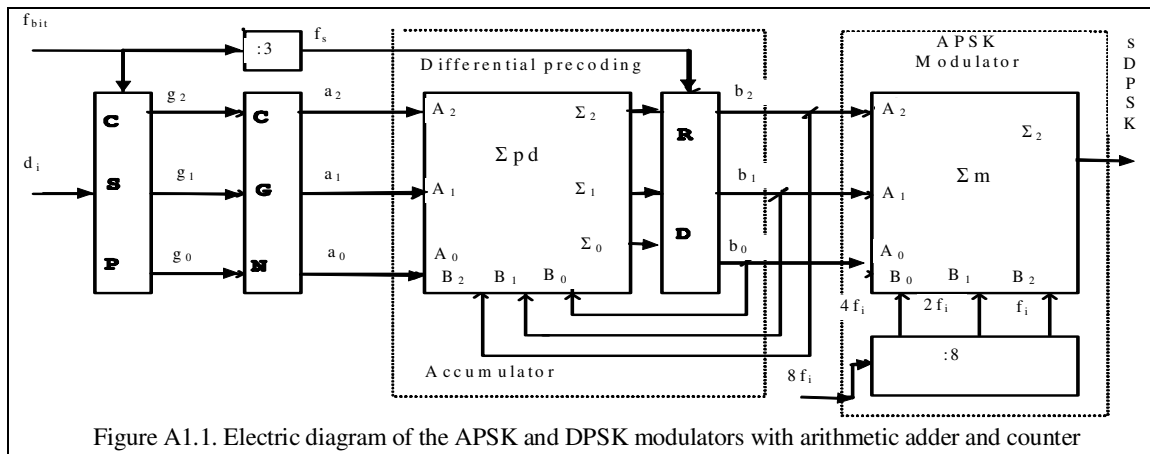

Figure A1.1. Electric diagram of the APSK and DPSK modulators with arithmetic adder and counter

shown in figure A1.1, for $p = 3$. The signal diagram is shown in figure A1.2.

- if the input tritbit b_i is kept to 000, the number 0 (expressed in natural-binary code) is added to the inputs of the adder; so, the Σ_2 output will deliver a rectangular signal of frequency f_i affected by a phase shift $\Delta\Phi = 0 \cdot 45^\circ$, compared to the reference signal, i.e. the signal at the counter output.
- if the tritbit = 100, then the number 4 is added and the sum will "suffer" a shift of four units, which equivalent to a phase-shift $\Delta\Phi = 4 \cdot 45^\circ = 180^\circ$, compared to the reference signal.
- similarly, for $b_i = 010$, a phase-shift $\Delta\Phi = 2 \cdot 45^\circ = 90^\circ$, and for $b_i = 001$, a phase-shift of $\Delta\Phi = 1 \cdot 45^\circ = 45^\circ$ is obtained.
- the combinations of the three bits generate all numbers $k \in \{0, \dots, 7\}$ that correspond to all the phase-

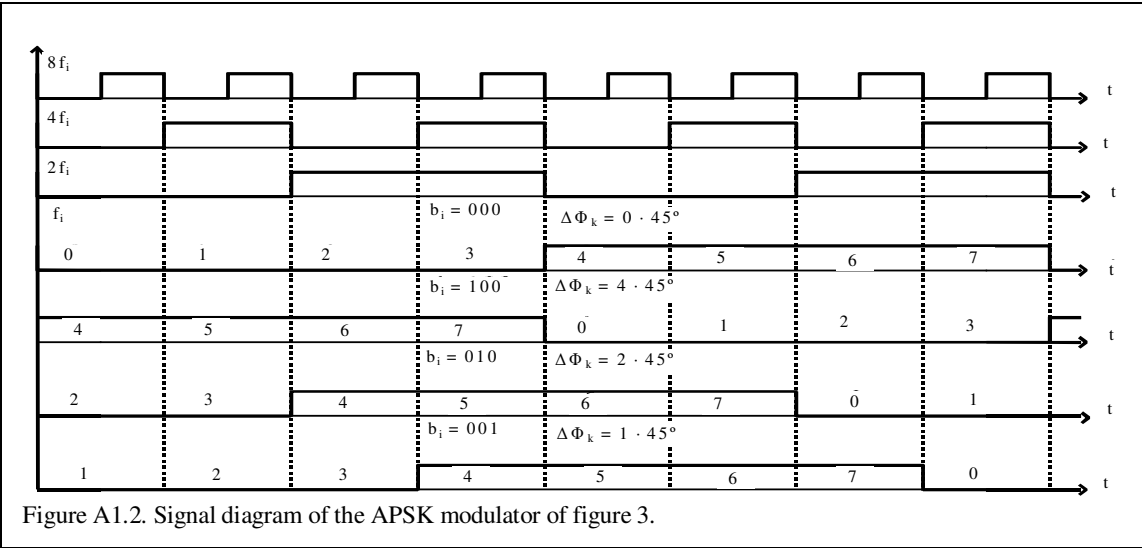

Figure A1.2. Signal diagram of the APSK modulator of figure 3.

shifts equaling $k \cdot 45^\circ$, which compose the A8 constellation.

- the conversion of the input tribit from the Gray-code to the natural binary code is required because the number k is the representation in the natural binary code of the data tribit.
- at the beginning of each symbol period, i.e. at the negative edge of the symbol-clock, the tribit a_i changes, generating the phase-shift corresponding to that period.
- *the phase-reference is the phase of the carrier f_i , so this modulator generates APSK.*
- to generate the DPSK modulated signal, the input data tribit a_i is differentially precoded, generating the tribit b_i which is applied to the APSK modulator, see figure 3. For the DPSK, the absolute phase of the carrier signal during the n -th symbol period may be written as:

$$\Phi_n^{\text{abs}} = (\Phi_{n-1}^{\text{abs}} + \Delta\Phi_n) \text{ modulo } 360^\circ; \quad (\text{A1.2})$$

- since all the phase-shifts are multiples of 45° , this can be simplified as:

$$k_n^{\text{abs}} = (k_{n-1}^{\text{abs}} + \Delta k_n) \text{ modulo } 8; \quad (\text{A1.3})$$

- so, the differential precoding consists of a modulo- 2^p arithmetic addition, on p bits, of the previous multibit b_{n-1} to the current multibit a_n that comes from the CGN.
- this operation is performed using a p -bit arithmetic adder and a p -bit shift register, as a memory element, see figure A1.1.
- if this modulator is to generate the A4 or A2 constellations, it should operate on 2 or 1 bit (the MSB ones); the differential precoding should be performed modulo 4 or, modulo 2. The inputs corresponding the unemployed bits should be connected to "0", i.e. $b_0 = "0"$ and $b_1 = b_0 = "0"$.
- the generation of the B-type constellations involves a rotation of 45° , for the B4, or of 90° , for the B2. This is accomplished by setting $b_0 = 1$, regardless the data dibit, for B4, or setting $b_1 = 1$ and $b_0 = 0$, for B2. For the constellations using 2 or 4 vectors, the significances of the three bits b_i are summarized in table A1.1, where d denotes data bits.

Bit↓; Constellation→	A8	A4	B4	A2	B2
b_2	d	d	d	d	d
b_1	d	d	d	0	1
b_0	d	0	1	0	0

Table A1.1. Values of tribit-bits for different constellations

- the frequency of the modulated carrier-signal f_i , may be either the channel carrier signal f_c or an intermediate frequency, higher than the channel-carrier frequency, depending of the method employed to filter the modulated signal, see the PSK-filtering paragraph.
- the AAC modulator inserts "advance" phase-shifts. Sometimes, "delay" phase-shifts should be inserted; to generate this type of phase-shifts we employ the periodicity of the carrier-signal and get (A.1.4), where the backwards phase-shifts are marked by '.

$$\Delta\Phi'_n = +(360^\circ - \Delta\Phi_n) \text{ modulo } 360^\circ; \rightarrow \Delta k'_n = (8 - \Delta k_n) \text{ modulo } 8; \quad (\text{A1.4})$$

- to get these phase-shifts the modulator should be provided with the 8-complement of the tribit that corresponds to the "advance" desired phase-shift. The block that performs the complement should be

placed between the CGN and accumulator.

- for constellations with 4 vectors the 4-complement should be employed; for B2, the modulating bit should be inverted and for A2 this operation is not required.

DPSK modulator built with an arithmetic adder and a shift-register - AASR

- its electric diagram is shown in figure A1.3 and the signal diagram is displayed in figure A1.4

- note that if the modulating functions $F_i = "0"$, the assembly AA-SR acts like an 8-counter.

- Considering the adder operational equation (A1.5), the B_i inputs of the adder increase their value with one unit in the rhythm of the $8f_i$ -clock signal, due to the input-carry $c_0 = 1$. Then the Σ_2 signal would have a period equaling 8 periods of the $8f_i$ signal, i.e. a frequency equaling f_i .

$$\Sigma_i = A_i \oplus B_i \oplus C_{i-1}; \tag{A1.5}$$

No. $8f_i$ -Ck Per	$F_0=F_1=F_2=0$ $\Sigma_2 \Sigma_1 \Sigma_0$	$F_0=1; F_1=F_2=0$ $\Sigma_2 \Sigma_1 \Sigma_0$	$F_0=F_2=0; F_1=1$ $\Sigma_2 \Sigma_1 \Sigma_0$	$F_0=F_1=0; F_2=1$ $\Sigma_2 \Sigma_1 \Sigma_0$
0	000	000	000	000
1	001	010	011	101
2	010	011	100	110
3	011	100	101	111
4	100	101	110	000
5	101	110	111	001
6	110	111	000	010
7	111	000	001	011
8(0)	000 (A)	001	010	100
$\Delta\Phi$	0°	45°	90°	180°

Table A1.2
Operating principle
of the AASR
DPSK modulator

- if at the beginning of the symbol-period, for a period of the $8f_i$ signal, $8f_i > f_s$, the modulating function $F_2 = "1"$,

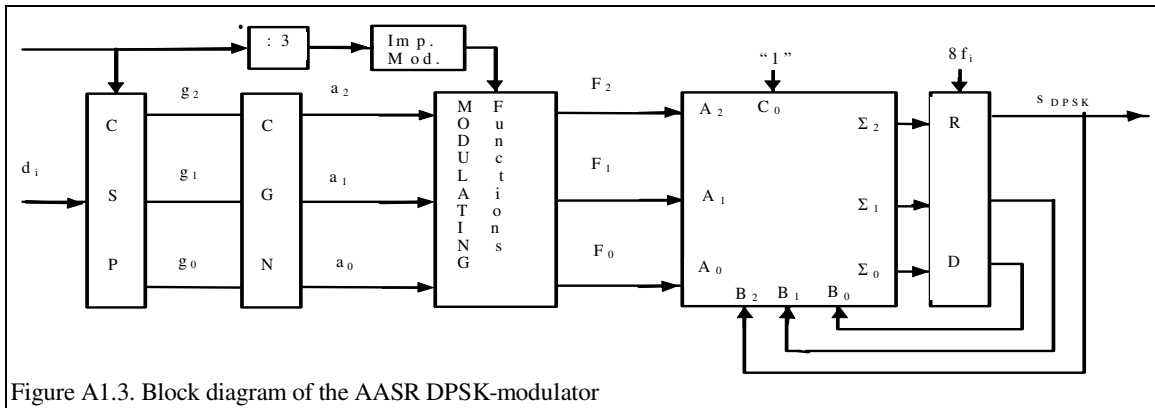

Figure A1.3. Block diagram of the AASR DPSK-modulator

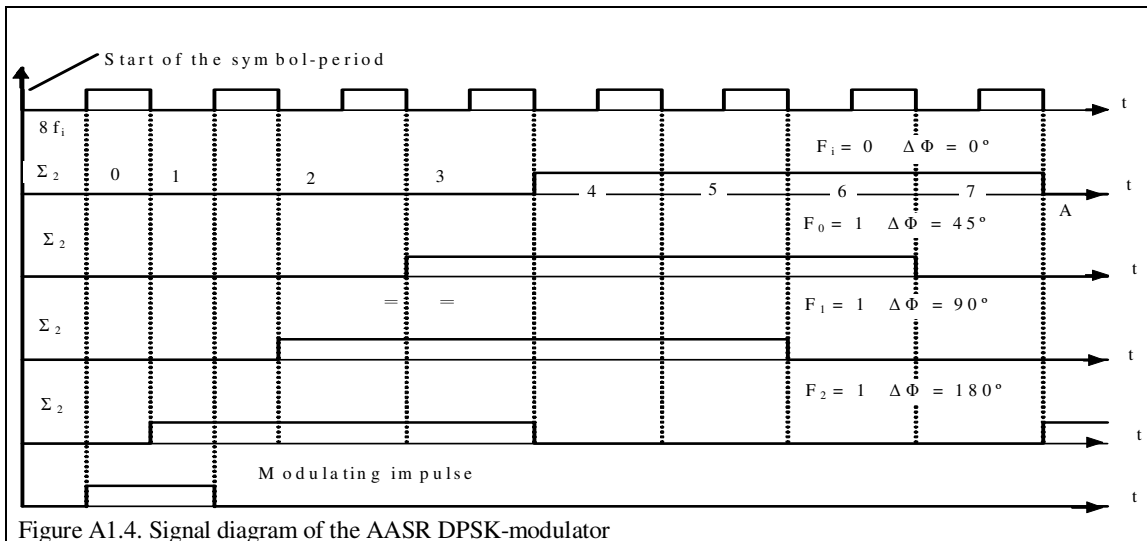

Figure A1.4. Signal diagram of the AASR DPSK-modulator

the adder output increases its value with 4 units and the phase of signal from the Σ_2 output suffers a

phase-shift, in advance, of $\Delta\Phi = 4 \cdot 45^\circ = 180^\circ$, see table A1.2 and figure A1.4. The phase-shift appears obvious if it is considered from the end of the first symbol period of the carrier signal (f_i), marked by point A in figure A1.4 and in table A1.2.

- Similarly, for $F_1 = 1$, we get $\Delta\Phi = 2 \cdot 45^\circ = 90^\circ$, and for $F_0 = 1$ we get $\Delta\Phi = 1 \cdot 45^\circ$.

- by combining the value of the three modulating functions, all the phase-shifts equaling $k \cdot 45^\circ$, with $k \in \{0, \dots, 7\}$ can be obtained.

- for this modulator, the modulating data tritbit is applied only during the modulation impulse, see figure 6; for the rest of the symbol period, the values of the modulating functions F_i , are forced to "0". So the tritbit a_i should be processed by the block that generates the modulating functions, which allow its access to the modulator only during the modulation impulse.

-the modulating function also perform the 8-complement (or 4-complement) if this modulator should insert backwards phase-shifts.

- the constellations with 4 or 2 vectors can be produced in the same manner as the one described for the AAC DPSK modulator, by taking into account table A1.1.

-because the phase-shift is referred to the phase of the carrier signal during the previous symbol period, considered to have $\Delta\Phi = 0^\circ$, this modulator generates a DPSK modulation.

DPSK modulator with controlled division – CD

- this modulator is based on the phase-shift by controlled division described in the dynamic synchronization system (see synchronization in the BB lecture notes).

Annex 2 Block diagram of a PSK transmitter - not required for examination

PSK transmitter with modulation on the intermediary frequency

- the block diagram of this transmitter is shown in figure A.2.1

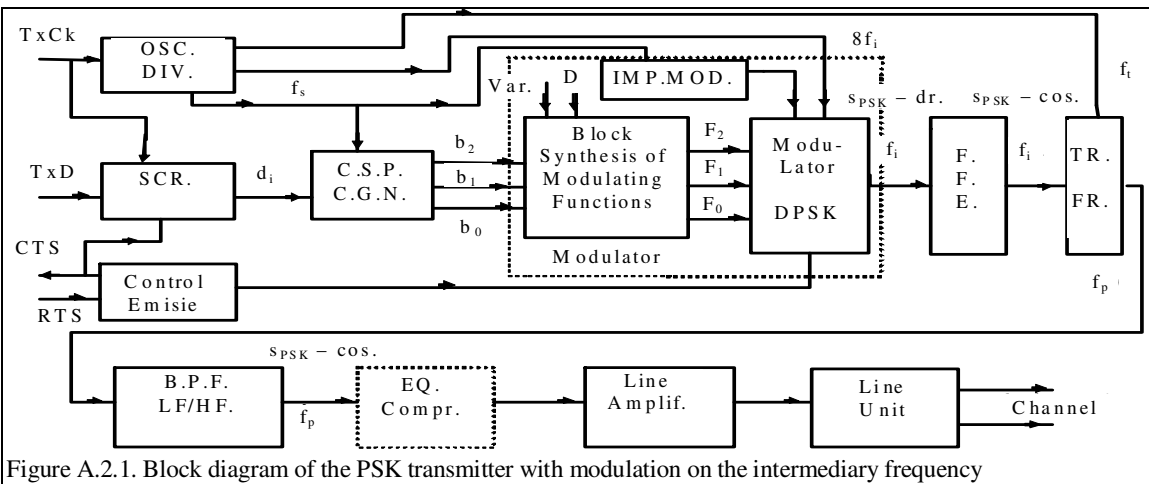

Figure A.2.1. Block diagram of the PSK transmitter with modulation on the intermediary frequency

- the data to be transmitted Tx D, are inserted into a scrambler SCR, that randomizes the data to be modulated. The scrambler is employed only for constellations with 8 or more vectors.

- the scrambled data are then sent to the series-parallel converter, then to the CGN generating the multibit which is delivered to the modulator.

- the modulator generates the modulated signal s_{PSK-f_i} on a rectangular carrier f_i , using the auxiliary signals of frequencies $8f_i$ and f_s , obtained from the oscillator-divider block, OSC-DIV.

- the modulated signal is filtered with a BP RRC filter with a roll-off factor α , by the transmission shaping-filter, FFE, generating a modulated signal on a cosine carrier signal, s-PSK,c, f_i .

- this signal is then translated on the channel-carrier frequency f_c by the frequency translation block TR.FR., which employs a rectangular signal of frequency f_i , provided by the OSC.-DIV block. The band-pass low-frequency filter BPF-LF, retains only the inferior sideband generated by the freq. trans., which is the modulated signal on a cosine carrier of frequency f_c , s-PSK,c, f_c .

- the level of this signal is established by the line amplifier; then the signal is sent to the line-unit which ensures the adaptation with transmission channel.

- the transmission control circuit manages the enable/disable of the transmitter, using the RTS and CTS signals. Some constructive variants include a compromise equalizer.