

PERFORMANCE ANALYSIS OF NETWORK CODING-BASED COOPERATION ALGORITHMS EMPLOYED IN CELLULAR NETWORKS

Mihai P. ȘTEF Anghel BOTOȘ Aurel VLAICU

Technical University of Cluj Napoca

15, Constantin Daicoviciu, Cluj Napoca, Romania, Tel. +40264401906, Mihai.Stef@com.utcluj.ro

Abstract: The employment of the network coding, combined with distributed FEC coding, in cooperative transmission schemes leads to a more efficient use of the additional time-frequency resources required by cooperation, i.e. by allowing a single relay node to serve two or more user terminals. This paper proposes a low complexity cooperation algorithm which employs network and distributed channel coding techniques in a two sources – one relay node cooperation scheme for the uplink connection of a cooperative cellular network. It also, provides a description and an analysis of the “mother” algorithm, Separate Network and Channel Coding (SNCC). The performance of the proposed cooperation algorithm is evaluated in terms of BER and PER in several significant scenarios. The performance provided by this algorithm is compared to the performance of non-cooperative coded transmission and to the performance of the “mother” algorithm, the SNCC algorithm.

Key words: cooperative diversity, channel coding, network coding, turbo codes

I. INTRODUCTION

Relaying and cooperation between terminals are considered as some of the most promising approaches for the improvement of the wireless networks performances. The channel-coded (CC) cooperation included in schemes where a relay-node (RN) serves only one mobile or fix user terminal (UT) in its transmission to the base station (BS) is one of the techniques proposed in literature to accomplish those improvements [1] [2]. Though this approach is shown to bring performance improvements for the served UT in terms of bit error rate (BER), packet error rate (PER) and/or coverage, the additional time-frequency resources (TFR) required by the RN are used to serve only one UT, leading to a loss of performances in terms of spectral efficiency. In order to decrease the effect of the additional TFR upon the spectral efficiency of the UT-BS transmission, Network Coding (NC) techniques [3] were included in coded cooperation algorithms. Since the NC techniques allow cooperation structures within which the RN serves more UTs, such an approach leads to a more efficient employment of the additional TFR of the RN. But, making these techniques effective raises new questions that have to be addressed.

The combined use of NC and channel coding was considered in several papers, e.g. [4] [5]. NC-based or joint NC-CC coding cooperation algorithms were proposed and their performances were studied in different scenarios, but some practical aspects are still not completely addressed. This paper considers the cooperative scheme within which one RN serves the uplink connections of two UTs, using combined NC and distributed CC (DCC) techniques. It proposes a low complexity cooperation algorithm which employs the NC and DCC techniques and compares the performances of the proposed algorithm with the ones of the “mother” algorithm (the SNCC algorithm) and the non-cooperative turbo coded

(TC) transmission in terms of BER and PER.

The paper is organized as follows: section II presents the scenarios employed for the performance evaluation of the proposed schemes. Section III describes the “mother” cooperative coding scheme, Separate Network and Channel Coding (SNCC). Section IV presents the proposed cooperative coding scheme, Low-complexity Separate Network and Channel Coding (LC-SNCC). Section V presents and discusses performance ensured by the considered cooperative schemes in terms of BER and PER vs. E_b/N_0 . Finally, section VI concludes the paper.

II. SCENARIOS

For the two sources-one relay (2S-1R) cooperation algorithms three scenarios, schematically illustrated in Figure 1, are considered.

These scenarios are intended to point out two major elements of a cooperation cluster, namely:

- The symmetry of the two sources UT^j , $j = 1, 2$, with respect to the base station BS; the UT^j are placed either symmetrically compared to the BS (Figure 1. left) or asymmetrically (Figure 1. right). In all scenarios, the UT^j are placed symmetrically with respect to the RN.
- The quality of the channels between the relay node (RN) and the user terminals (UT^j), i.e. they are considered to be quasi error-free (EF) or they are supposed to be affected by errors (WE).

In all scenarios, the UT^j -RN channels are considered AWGN channels, while the UT^j -BS and RN-BS channels are considered to be AWGN also affected by block fading. The employed modulation on all the links is 2-PSK.

The first scenario, SS-EF (Figure 1. left), consists of quasi error-free UT^j -RN channels and identical UT^j -BS channels. The E_b/N_0 of the UT^j -RN channels is set to 20 dB, so that the BER of the modulation scheme considered would be small

enough to validate this assumption.

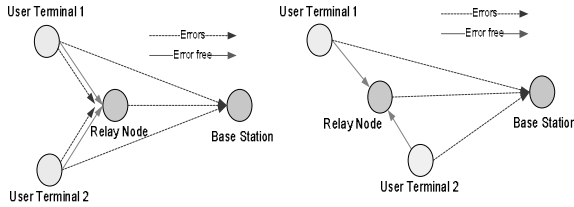

Figure 1. Employed scenarios for the performance evaluation

The RN-BS channel is better than the UT^1 -BS channels, i.e. the E_b/N_0 of the RN-BS channel is with 6dB higher than the ones of the UT^1 -BS channels:

$$(E_b / N_0)_{RN \rightarrow BS} = (E_b / N_0)_{UT^1 \rightarrow BS} + 6dB \quad (1)$$

The second scenario, AS-EF (Figure 1. right), considers that the UT^1 -BS channel is “worse” than UT^2 -BS and the RN-BS channels; and UT^2 -BS channel is “better” than RN-BS channel. The relations between the E_b/N_0 values of the involved channels are:

$$\begin{aligned} (E_b / N_0)_{RN \rightarrow BS} &= (E_b / N_0)_{UT^1 \rightarrow BS} + 6dB \\ (E_b / N_0)_{UT^2 \rightarrow BS} &= (E_b / N_0)_{UT^1 \rightarrow BS} + 12dB \end{aligned} \quad (2)$$

The asymmetrical positions of the two UTs were chosen to point out the influence of a „well positioned” UT upon the cooperative gain ensured for a „badly positioned” UT.

The third scenario, SS-WE (Figure 1 left) is identical with the first one but assumes that UT^1 -RN channels are affected by errors. Two simulations were performed for this scenario, for two different values of E_b/N_0 on channels UT^1 -RN, namely E_b/N_0 was set to 6 dB (simulation 1) and to 4.5 dB (simulation 2), generating BER values of about $3 \cdot 10^{-3}$ and 10^{-2} , respectively.

All these scenarios are for the uplink transmission. The channels configurations for all three scenarios are summarized in Table 1.

These scenarios were chosen in a manner that would allow pointing out the effects of two important factors of a cooperative approach, namely the effects of the errors that might occur on the UT^1 -RN channel and the influence of the quality of the UT^2 -BS channel, upon the performances of the UT^1 , which has a poorer channel.

Channel/Channel type	SS-EF	AS-EF	SS-WE	
	E_b/N_0 domain	E_b/N_0 domain	E_b/N_0 domain - simulation 1	E_b/N_0 domain - simulation 2
UT^1 -RN AWGN	20 dB	20 dB	6 dB	4.5 dB
UT^2 -RN AWGN	20 dB	20 dB	6 dB	4.5 dB
UT^1 -BS AWGN, Block fading	[0dB; 15dB]	[0dB; 15dB]	[0dB; 15dB]	[0dB; 15dB]
UT^2 -BS AWGN, Block fading	[0dB; 15dB]	[12dB; 27dB]	[0dB; 15dB]	[0dB; 15dB]
RN-BS AWGN, Block fading	[6dB; 21dB]	[6dB; 21dB]	[6dB; 21dB]	[6dB; 21dB]

Table 1. Channel configuration for the employed scenarios

III. SEPARATE NETWORK AND CHANNEL CODING

This algorithm employs separately distributed channel coding and network coding and also considers that a RN serves two UTs. It is based on the method proposed in [8] and also discussed in [4] [6] and [7]. Its operating principle is described below, using Figure 2 that presents its block diagram.

Each UT encodes his N_i information bits, using the same turbo encoder and puncturing pattern so that the coding rate would be R_{UT} and sends their N_{UT} length coded blocks over UT^1 -RN channels and UT^1 -BS channels

The BS saves the blocks decoded on the direct links, using the corresponding turbo-decoders (see Figure 2), and waits for the additional information that should be received from the RN using network coding.

The RN decodes the data received from each user and combines the two data flows using an XOR operation, which is a simple form of network coding:

$$x_{k,RN} = x_{k,UT^1} \oplus x_{k,UT^2}, k = \overline{1, N_i} \quad (3)$$

Then it encodes the combined data using the same mother turbo code as the one employed by the UTs. The encoded data flow is then punctured, using the same puncturing pattern, generating a coding rate of R_{UT} . The N_{UT} -long coded block obtained is then sent over the RN-BS channel.

The BS decodes the blocks received on the two direct links, using the corresponding turbo-decoders, checks their integrity (potentially using a CRC), saves them and waits for the additional information that should be received from the RN using network coding. Then, the BS turbo-decodes the block received from the RN, checks its integrity and then the three data flows, i.e. UT^1 -BS, UT^2 -BS and RN-BS, are network decoded.

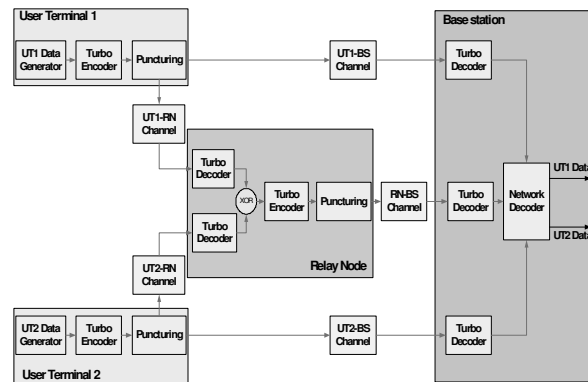

Figure 2. Coded cooperation scheme based on the Separate Network and Channel Coding algorithm

The network decoding process assumes that two of the three data flows are correctly decoded, and therefore it extracts the third flow by an XOR operation. The possible alternatives in the decoding process are summarized below:

- If the UT^1 block has errors and UT^2 and RN blocks are correctly turbo-decoded, the UT^1 block is obtained from the other two blocks using an XOR operation, see (3).
- If the UT^2 block has errors and UT^1 and RN blocks are

correctly turbo-decoded, the UT^2 block is obtained from the other two blocks by using an XOR operation.

If both UT^1 and UT^2 are correctly decoded, the block received on the RN-BS channel is no longer employed.

This scheme allows the RN to serve two users while still using only one resource allocation unit.

The global rate of this scheme can be obtained as follows: for decoding the two N_i bits length information blocks three N_{UT} bits length coded blocks are sent.

$$R_g = \frac{2 \cdot N_i}{3 \cdot N_{UT}} = \frac{R_{UT}}{1.5} \quad (4)$$

Analysis of the packet error rate (PER) provided by the SNCC algorithm with the number of UTs served by one RN and comparison to (with) the PER provided by the uncooperative transmission is of interest. For this analysis we assume a scenario with N mobile stations $UT^j, j=1, \dots, N$, served by an RN that uses the SNCC algorithm, as shown in figure 3.

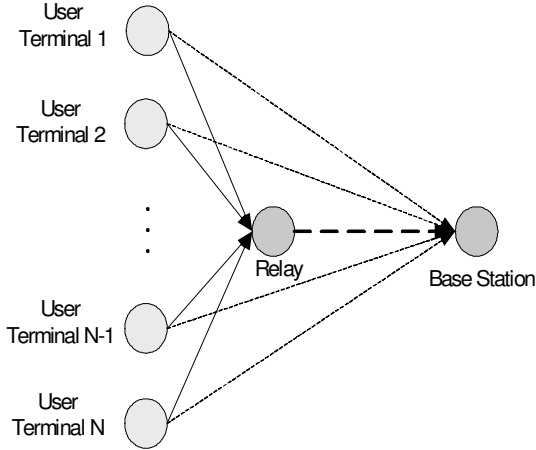

Figure 3. N user terminal scenario

A packet transmitted by the $UT^j, j=1, \dots, N$ is correctly decoded by the SNCC either if the packet is correctly decoded by the decoder of its direct UT^j -BS link or if the packet on that link is wrongly decoded and all packets transmitted on the other UT^j -BS direct links and on the RN-BS link are correctly decoded. Then the packet error rate on the UT^j -BS link can be expressed by (5), where PER_{xx} denotes the packet error rate on the respective link

$$PER_{SNCC}^{UT_j} = 1 - \left[\left(1 - PER_{UT_j} \right) + PER_{UT_j} \cdot \left(1 - PER_{RN} \right) \cdot \prod_{\substack{i=1 \\ i \neq j}}^N \left(1 - PER_{UT_i} \right) \right] = PER_{UT_i} - PER_{UT_i} \cdot \left(1 - PER_{RN} \right) \cdot \prod_{\substack{i=1 \\ i \neq j}}^N \left(1 - PER_{UT_i} \right) \quad (5)$$

The PER improvement brought by the SNCC scheme can be expressed by the PER Improvement Factor, $PERIF_{SNCC}^{UT_j}$

which is defined as the ratio between the PER provided on the UT^j -BS link by the SNCC algorithm and the PER of the direct link PER_{UT_j} , i.e.:

$$PERIF_{SNCC}^{UT_j} = \frac{PER_{SNCC}^{UT_j}}{PER_{UT_j}} = \frac{PER_{UT_j} - PER_{UT_j} \cdot \left(1 - PER_{RN} \right) \cdot \prod_{\substack{i=1 \\ i \neq j}}^N \left(1 - PER_{UT_i} \right)}{PER_{UT_j}} = \left(1 - PER_{RN} \right) \cdot \prod_{\substack{i=1 \\ i \neq j}}^N \left(1 - PER_{UT_i} \right) = 1 - \frac{PER_{UT_j}}{PER_{UT_j}} \Rightarrow PER_{SNCC}^{UT_j} = PERIF_{SNCC}^{UT_j} \cdot PER_{UT_j}$$

The inverse of this factor shows how many times the PER of the direct link is decreased by the SNCC algorithm.

There should be noted that the $PERIF$ increases with the increase of the number of UTs served by the relay, because $0 < 1 - PER_{UT_j} < 1$. Therefore, the number of UTs served by an RN within this algorithm should be small. Considering also the signaling issues and the problems raised by the relay-assignment algorithm, the number of UTs served by one RN should be limited to two.

IV. LOW-COMPLEXITY SEPARATE NETWORK AND CHANNEL CODING

The basic idea of this algorithm is to reduce the complexity of the SNCC algorithm, by using the linearity property of the turbocodes, i.e. a linear combination of two codewords generates another valid codeword.

By using the soft network coding concept, [5], the complexity required by the implementation of the SNCC algorithm in the RN and BS is significantly decreased. Figure 4 presents the schematic diagram of this algorithm.

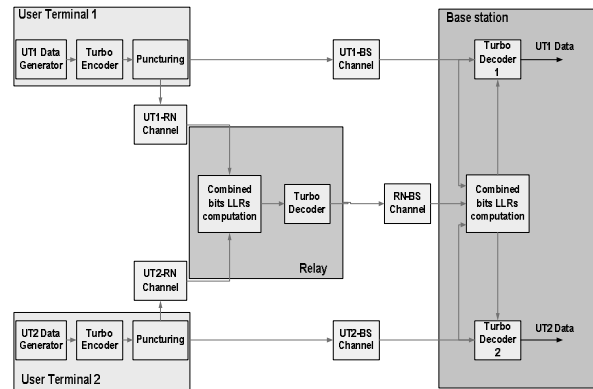

Figure 4. Coded cooperation scheme based on the Low-Complexity Separate Network algorithm

Considering the turbocode linearity and the fact that the

network coding process is a linear mapping, the order of these coding processes can be exchanged as shown in [5], compared to their order in the SNCC algorithm, see section III. This inversion can be accomplished by extracting at the RN the LLRs of data received from UT^1 (X_1) and UT^2 (X_2), then computing the LLRs of the network encoded flows and using these network encoded LLRs as input information for the RN's turbo decoder.

The log-likelihood ratio of $X_1 \oplus X_2$ can be expressed, based on the UT^j -RN channels' observations, as in [5]:

$$LLR_{X_1 \oplus X_2} = \ln \left(\frac{1 + e^{(LLR_{X_1} + LLR_{X_2})}}{e^{LLR_{X_1}} + e^{LLR_{X_2}}} \right) \approx \text{sign}(LLR_{X_1}) \cdot \text{sign}(LLR_{X_2}) \cdot \min(|LLR_{X_1}|, |LLR_{X_2}|) \quad (7)$$

By turbo-decoding the set of LLRs we obtain the network encoded block which is transmitted over the RN-BS channel without any channel encoding. This is a second modification of the SNCC algorithm aimed to decrease the implementation complexity in the RN

The BS, equipped with only two turbodecoders, as opposed to the three turbodecoders required by the SNCC algorithm, extracts the LLRs from the signals received on the direct UT^j -BS channels and on the RN-BS channel. Then, the LLRs of the RN-BS channel are used to compute the additional information for the two turbodecoders of the two data flows by using (7), as shown in (8).

$$LLR_{additional}^{UT1} = \ln \left(\frac{1 + e^{(LLR_{RN} + LLR_{UT2})}}{e^{LLR_{RN}} + e^{LLR_{UT2}}} \right) \quad (8)$$

$$LLR_{additional}^{UT2} = \ln \left(\frac{1 + e^{(LLR_{RN} + LLR_{UT1})}}{e^{LLR_{RN}} + e^{LLR_{UT1}}} \right)$$

The two flows are separately turbodecoded using the direct channel observations and the additional LLRs computed using the other channel's observations.

By using the approximation in (7), the complexity of the computation of the additional LLRs block is drastically reduced. Because the RN data block is sent without any channel encoding, the global coding the cooperation scheme increases, compared to the one ensured for SNCC, (4); and it can be computed by:

$$R_{eg} = \frac{2 \cdot N_i}{2 \cdot N_{UT} + N_i} = \frac{2 \cdot N_i \cdot R_{UT}}{2 \cdot N_i + R_{UT} \cdot N_i} = \frac{2 \cdot R_{UT}}{2 + R_{UT}} \quad (9)$$

V. PERFORMANCE ANALYSIS OF THE SNCC AND LC-SNCC ALGORITHMS

The performance of the SNCC and LC-SNCC algorithms are evaluated in the scenarios discussed in section II. The non-cooperative turbo coded (TC) transmission performance is used as reference for all considered scenarios. The parameters of the RSC code and those of the simulations are summarized in table 2.

The E_b/N_0 of the studied UT^1 , the reference channel of each simulation, was varied within the limits defined in Table 1 for each scenario on a block Rayleigh-faded channel. The E_b/N_0 values of the other channels involved are kept greater than the ones of the reference channel with the amounts specified in Table 1.

Feedback generator polynomial	13 ₈
Feedforward generator polynomial	15 ₈
“Mother” code rate	0.50
UT coding rate	0.75
No. of iterations of the turbodecoders	8
No. of blocks for each E_b/N_0 value	2000
No. of info bits/block	1500

Table 2. Parameters of the employer coding schemes

V.a BER and PER Performance in the SS-EF Scenario

Figures 5 and figure 6 present the BER and PER performance of LC-SNCC and SNCC algorithms for SS-EF scenario. Since the two UTs have identical parameters, their performance would be similar and therefore only the performance of UT^1 is shown.

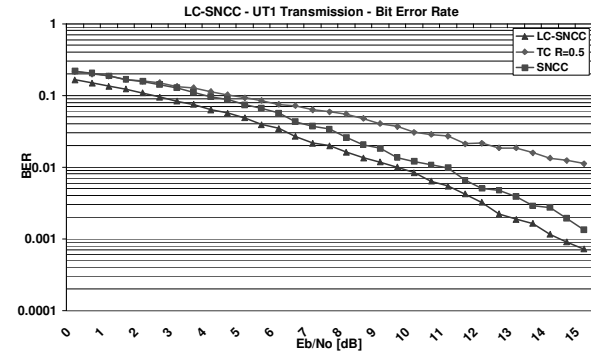

Figure 5. The BER performance of UT^1 transmission for SS-EF scenario

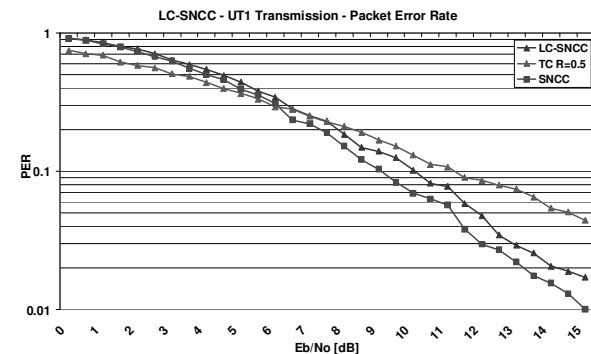

Figure 6. The PER performance of UT^1 transmission for SS-EF scenario

The LC-SNCC algorithm outperforms both, the SNCC and TC algorithms in terms of BER, providing approx. 5 dB gain for a bit error rate equal to 10^{-2} compared to TC transmission. The PER performance of the LC-SNCC is slightly worse than the one of SNCC algorithm, but outperforms the TC transmission. This behavior might be explained by the

different distribution of the bit-errors within packets.

V.b BER and PER Performance in the AS-EF Scenario

Since the UT¹-BS direct channels of the two UTs have significantly different E_b/N₀ values, see Table 1, the performance of the two UTs are expected to be different and therefore they will be presented separately in figures 7 - 10.

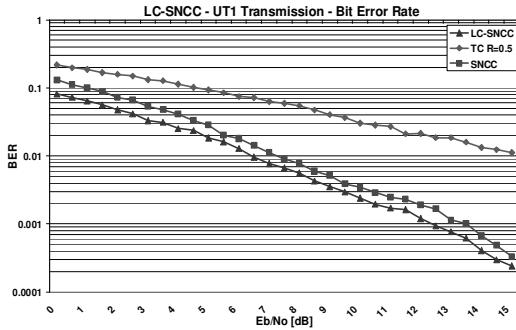

Figure 7. The BER performance of UT¹ transmission for AS-EF scenario

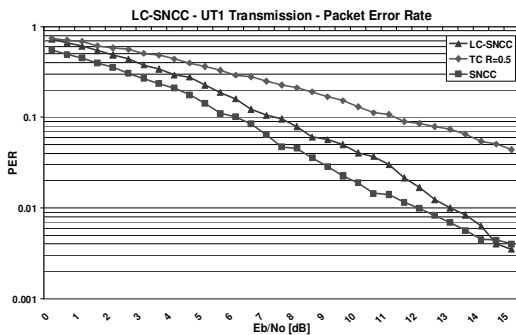

Figure 8. The PER performance of UT¹ transmission for AS-EF scenario

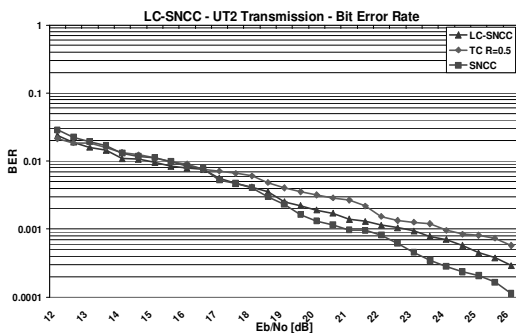

Figure 9. The BER performance of UT² transmission for AS-EF scenario

For UT¹ transmission, the LC-SNCC algorithm provides a significant cooperative coding gain (CCG), in terms of BER, of approximately 8 dB compared to TC scheme and 0.7 dB compared to the SNCC algorithm performance. This is explained by the fact that UT² provides “better quality” cooperation, due to its “better” position. The smaller gain provided for UT², of about 1 dB, is due to the better

performance of the reference transmission, which has a better UT²-BS channel and to the „smaller help” received from UT¹. The performance of the LC-SNCC algorithm is slightly worse for the “better positioned” UT, i.e. UT². As for the PER performance, the SNCC outperforms, both the LC-SNCC algorithm and the non-cooperative TC transmission.

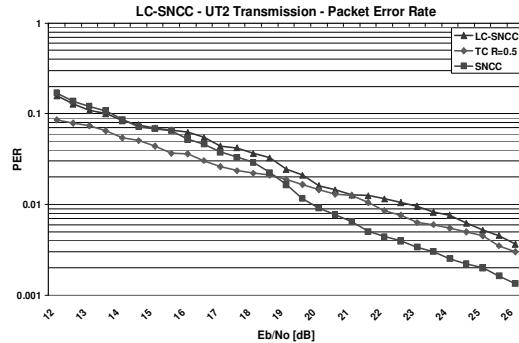

Figure 10. The PER performance of UT² transmission for AS-EF scenario

The obtained results, can be summarized as follows:

- The LC-SNCC provides smaller BER than SNCC for UT¹, (a CCG greater with 1 dB), while for UT² it provides higher BER, (a CCG smaller with 1 dB)
- The LC-SNCC ensures higher values of PER than SNCC for both UTs involved. This decrease of the PER performance, compared to the one of the SNCC, could be explained by the absence of the error detection mechanism on the direct and relay channels

V.c BER and PER Performance in the SS-WE Scenario

Since the two UTs have identical parameters, their performance would be similar and therefore only the performance of UT¹ is shown.

Figure 11 and figure 12 present the BER and PER performance provided by the LC-SNCC and the SNCC algorithms for UT¹ in this scenario, for simulation 1 (Table 1) and figure 13 and 14 for simulation 2 (Table 1). The corresponding values of BER on UT¹-RN channels are 3·10⁻³ and 10⁻², see section II. The figures also show the performance of the direct turbocoded transmission, TC as reference.

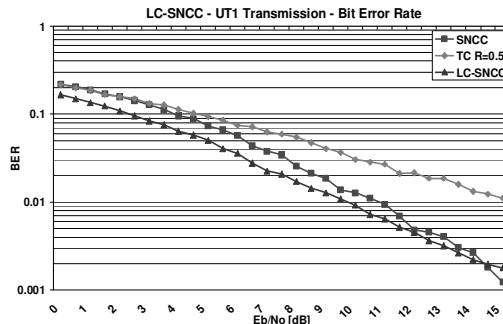

Figure 11. The BER performance of UT¹ transmission for SS-WE scenario, simulation 1

If the E_b/N₀ of UT¹-RN is above a threshold value, see simulation 1 (figure 11), the LC-SNCC provides a CCG of

about 5 dB, compared to TC transmission at a BER of 10^{-2} while if it is below that threshold, the BER performance of the LC-SNCC becomes worse than the one of direct transmission TC and of the one of the SNCC algorithm, exhibiting an error-floor, see simulation 2 (figure 13).

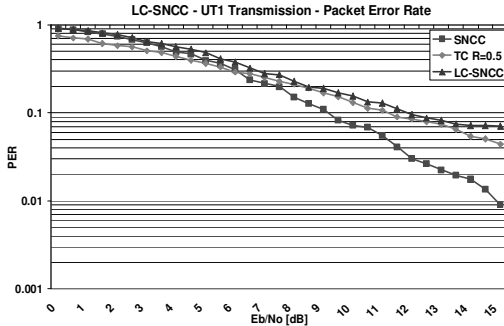

Figure 12. The PER performance of UT¹ transmission for SS-WE scenario, simulation 1

As for the PER performance, the LC-SNCC performs worst than the SNCC and TC.

The error detection mechanism of SNCC scheme on the direct and relay links make this scheme less sensitive to the UTs-RN channels quality. Another cause of the poorer performance obtained by the LC-SNCC in this scenario is that the error correcting power of the code used on the UTs-RN link is poorer, as shown in [5], due to the combination of the two blocks before the channel decoder.

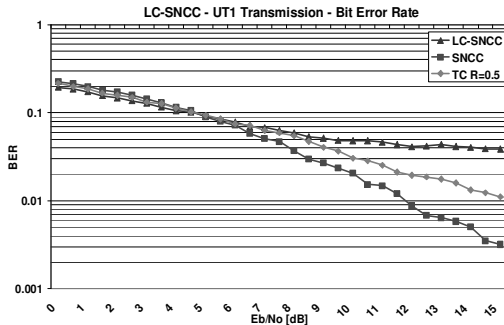

Figure 13. BER of UT¹ transmission for SS-WE scenario, simulation 2

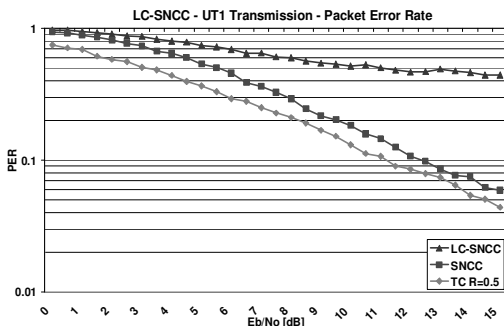

Figure 14. PER of UT¹ transmission for SS-WE scenario, simulation 2

VI. CONCLUSIONS

The paper describes and analyzes the Separate Network and Channel Coding (SNCC) algorithm and proposes a model for Packet Error Rate (PER) evaluation, based on direct links and relay link PER.

Also, the paper proposes a low complexity cooperation algorithm, LC-SNCC, which employs network coding and distributed channel coding techniques. This algorithm is a modified version of the SNCC algorithm that aims to decrease the implementation complexity especially in the relay node, being more appropriate for integration in cellular networks using non-dedicated relays.

The LC-SNCC algorithm requires a simpler implementation, since it uses only one turbo decoder and two soft-demapping circuits in the RN and only two decoder and three soft-demapping circuits in the BS. The complexity of the UT is similar to the one required by SNCC algorithm.

As was shown in the paper for quasi error free UTs-RN channel scenarios LC-SNCC performs better in terms of BER, than the SNCC algorithm, but the PER performances are slightly poorer than the ones of the SNCC. In the case of the “with errors” scenarios the LC-SNCC seems to be more sensitive to the UTs-RN channels quality due the absence of the error detection mechanisms and the decreased error correcting power of the codes employed on these links.

By employing the LC-SNCC algorithm, the global coding rate of the cooperation scheme increases and thus a nominal spectral efficiency higher than the one provided by the SNCC algorithm is ensured.

ACKNOWLEDGMENT

This work was partially funded by the European Union within FP7-ICT-215477 CODIV Project.

REFERENCES

- [1] B. Zhao, M.C. Valenti, “Distributed turbo coded diversity for relay channel”, Electronics Letters, vol. 39, 15 May 2003
- [2] Arnab Chakrabarti, Elza Erkip, Ashutosh Sabharwal, and Behnaam Aazhang, “Code Designs for Cooperative Communication”, IEEE Signal Processing Magazine, Vol. 24, Issue 5, Sept. 2007, pp. 16 - 26
- [3] R. Ahlswede, N. Cai, S.-Y. R. Li and R. W. Yeung, “Network information flow”, IEEE Transactions on Information Theory, 46(4):1204-1216, July 2000.
- [4] Christoph Hausl, Philippe Dupraz, “Joint Network-Channel Coding for the Multiple-Access Relay Channel”, SECON 2006, Vol. 3, pp. 817-822
- [5] Shengli Zhang, Yu Zhu, Soung-Chang Liew, and Khaled Ben Letaief, “Joint Design of Network coding and channel decoding for wireless networks”, IEEE WCNC, 2007
- [6] M.P. Stef, Zs. A. Polgar, V. Bota, “Performance Analysis of Some Distributed Network and Channel Coding Schemes in Cooperative Transmissions”, COST 2100 TD(08) 654, Lille, France, 2008
- [7] “Preliminary PHY layer algorithm selection for integration in the prototypes”, Deliverable D.3.2a, FP7-ICT-2007-215477, CODIV Project. www.ict-codiv.eu
- [8] Yingda Chen, Shalinee Kishore and Jing (Tiffany) Li, “Wireless Diversity through Network Coding”, IEEE Wireless Communications and Networking Conference, 2006