

Local carrier synchronization

- the synchronization of the local carrier, required for the demodulation of all square and „cross” constellations, may be accomplished by two types of methods:

- methods that employ pilot signals
- methods that employ only the received signal.

- the methods that employ pilot signals require additional frequency bandwidth and would not be discussed here. Some of the methods of this type are presented in [con].

- The synchronization of the local carrier involves two operations:

- extraction of a phase-reference signal out of the received signal, called recovery; this signal is delivered to the phase-comparator of a PLL circuit.
- synchronization of locally generated signal, of frequency f_c , by means of a PLL circuit, using as phase-reference the signal recovered in the previous operation.

- the carrier recovery only from the received signal may be accomplished by two methods:

- by raising the received signal at the fourth power followed by a BP filtering – it delivers a signal of $4 f_c$ frequency which is employed by the PLL circuit as a phase-reference – see the DT lectures.
- the „decision directed carrier recovery” (DDCR) method, which directly computes an error-voltage that controls a local oscillator to obtain the synchronized signal of frequency f_c . The PLL closes over the probing and decision blocks of the QAM demodulator.

Decision directed local-carrier recovery -DDCR

- this recovery method employs the baseband probed signals I'_k and Q'_k , and the decided levels, I_k^* and Q_k^* , indicated in figure 6 of the previous lecture on A+PSK.

- its operational principle is based on the assumption that the differences between the probed levels and the decided ones are only owed to the phase-shift between the received carrier and the local carrier, which is defined by:

$$\omega_l \cdot t = \omega_c \cdot t + \Delta\omega \cdot t + \Theta_0 = \omega_c \cdot t + \Theta(t); \quad (1)$$

- the probed levels I'_k , Q'_k can be expressed, in terms of the $\Theta(t)$ and modulating levels, by relations (33), see DPSK-QAM lectures:

$$I'_k = I_k \cos\Theta(kT) + Q_k \sin\Theta(kT); \quad Q'_k = I_k \sin\Theta(kT) - Q_k \cos\Theta(kT); \quad (2)$$

- in the DPSK-QAM lectures, an error voltage expressed by (3) was computed in the assumption that the symbol-clock is perfectly recovered, i.e. the probing is performed at $t = kT_s$:

$$e_k = I'_k \cdot Q_k^* + Q'_k \cdot I_k^* = I_k \cdot Q_k^* \cdot \cos\Theta_k + Q_k \cdot Q_k^* \cdot \sin\Theta_k + I_k \cdot I_k^* \cdot \sin\Theta_k - Q_k \cdot I_k^* \cdot \cos\Theta_k \approx (I_k^{*2} + Q_k^{*2}) \cdot \sin\Theta_k \quad (3)$$

- note that in (3) the probing moments are considered $t = kT_s$ so a shift of $T_s/2$, relative to the modulating moments, was applied to the time reference, due to the RC filtering.

- if we considered an imperfect symbol-clock recovery, i.e. the probing is performed at $t = kT_s + \tau$ (τ being positive or negative), the probed modulating levels would be expressed by (4), where $h(\tau)$ is the impulse response of the RC filter at $t = \tau$. Note that in (4) $h(\tau) < h(0) = 1$.

$$I'_k = I_k \cdot h(\tau) \cdot \cos\Theta(kT) + Q_k \cdot h(\tau) \cdot \sin\Theta(kT); \quad Q'_k = I_k \cdot h(\tau) \cdot \sin\Theta(kT) - Q_k \cdot h(\tau) \cdot \cos\Theta(kT); \quad (4)$$

- the voltage error defined in (4), would be expressed by (5) for an incorrect probing moment $t = kT_s + \tau$:

$$e_k = I'_k \cdot Q_k^* + Q'_k \cdot I_k^* = h(\tau) \cdot [I_k \cdot Q_k^* \cdot \cos\Theta_k + Q_k \cdot Q_k^* \cdot \sin\Theta_k + I_k \cdot I_k^* \cdot \sin\Theta_k - Q_k \cdot I_k^* \cdot \cos\Theta_k] \approx \approx h(\tau) \cdot (I_k^{*2} + Q_k^{*2}) \cdot \sin\Theta_k = h(\tau) \cdot A_k^2 \cdot \sin\Theta_k; \quad (5)$$

- the above relation assumes that the decisions are correct and the two probed levels are identically affected by the channel; these assumptions allow the reduction of the terms that contain the cosine of $\Theta(kT_s)$.

- this voltage cannot be employed for a proportional phase-control of a VCO due to the non-linearity of the sinus function.

- since, for $\Theta \in (-\pi/2, +\pi/2)$, the sign of the error-voltage is the same as the one of the phase-shift $\Theta(t)$, this voltage could be employed to control a dynamic synchronization circuit which would shift the phase of the local carrier with a constant step $\Delta\phi_p$ according to the polarity of the error-voltage, see the BB lectures.

- the block diagram of the recovery and synchronization circuit based on this method is shown in figure 7.

- the sign of e_k is employed to indicate the direction of the phase-shift inserted by the controlled divider, operation performed by the control circuit; this approach ensures the modification of local-carrier's phase with a constant phase-shift, until it enters into the equilibrium zone, or the maintenance of the local carrier's phase inside that region.

- this method could insert an additional uncertainty of π , see DPSK-QAM lectures; besides, an additional $\pi/2$ uncertainty might occur. These show that this recovery-synchronization method also inserts $k \cdot 90^\circ$ rotations.

- the method provides good results only for medium or small values of the symbol-error probability, requiring medium or high quality channels.

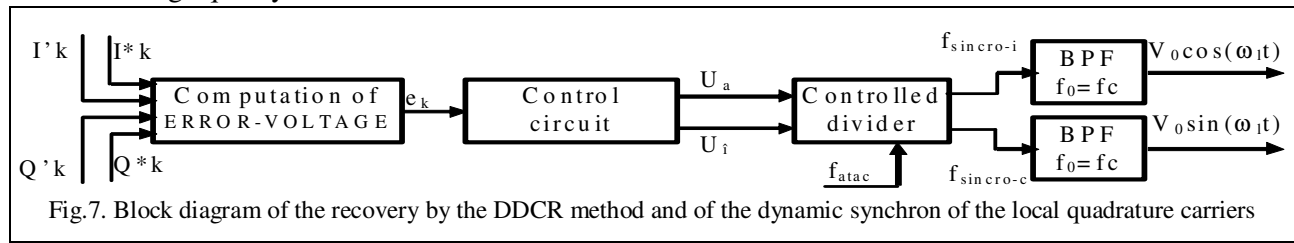

Fig.7. Block diagram of the recovery by the DDCR method and of the dynamic synchron of the local quadrature carriers

- on „difficult” channels the symbol-error-probability increases, making the approximation of (5) too rough, and the control-voltage might have a wrong (opposite) sign. This leads to wrong phase-corrections and, finally, to the non-convergence of the local-carrier synchronization. These facts make the method appropriate only for channels that are not affected by severe fading.

- some terrestrial and mobile radio channels that are affected by severe fading, require the use of another recovery method or recovery methods that use pilot signals, see the DT lectures.

Symbol-clock recovery and synchronization

- because some carrier-recovery methods are based on the probed and decided symbols, their performances are affected by the quality of the symbol-clock recovery and synchronization.

- to avoid the „vicious circle” described in the DPSK-QAM lectures, which might lead to the non-convergence of the whole receiver, the symbol clock recovery methods should not rely on the quality of the recovered local carrier, as in the QPSK case.

- some symbol-clock recovery methods that are not affected by the carrier recovery and some considerations regarding the synchronization accuracy will be discussed in the DT lectures.

- below we present a version of the DDCR method adapted for the recovery of this symbol-clock

Decision-Directed Symbol-Clock Recovery DDSCkR

- the DD symbol-clock recovery is similar to the DD carrier recovery, but uses the derivative of the received modulated signal signal. The method is described below for only one symbol period

- by performing the derivative of the demodulated signals expressed by (2) we get (6), where $\Theta'(t)$ equals a constant, i.e., $\Delta\omega$, see (1):

$$(I_k'(t))' = (I_k(t))' \cdot \cos(\Theta(t)) - I_k(t) \cdot (\Theta(t))' \cdot \sin(\Theta(t)) + (Q_k(t))' \cdot \sin(\Theta(t)) + Q_k(t) \cdot (\Theta(t))' \cdot \cos(\Theta(t)) \quad (6)$$

$$(Q_k'(t))' = (I_k(t))' \cdot \sin(\Theta(t)) + I_k(t) \cdot (\Theta(t))' \cdot \cos(\Theta(t)) - (Q_k(t))' \cdot \cos(\Theta(t)) + Q_k(t) \cdot (\Theta(t))' \cdot \sin(\Theta(t))$$

- by probing these signals at time instants shifted with τ from the ideal probing moments, i.e at $t = kT_s + \tau$ instead of kT_s , we get the the expressions \mathcal{I}_k and \mathcal{Q}_k of the values of the derivative of $I'(t)$ and $Q'(t)$:

$$\mathcal{I}_k = (I_k')'(kT_s + \tau) = (h')(\tau) \cdot [I_k \cos(\Theta(t)) + Q_k \sin(\Theta(t))] - (\Theta(t))' \cdot [I_k h(\tau) \cdot \sin(\Theta(t)) - Q_k h(\tau) \cdot \cos(\Theta(t))] \quad (7)$$

$$\mathcal{Q}_k = (Q_k')'(kT_s + \tau) = (h')(\tau) \cdot [I_k \sin(\Theta(t)) - Q_k \cos(\Theta(t))] + (\Theta(t))' \cdot [I_k h(\tau) \cdot \cos(\Theta(t)) + Q_k h(\tau) \cdot \sin(\Theta(t))] \quad (8)$$

- we define, similarly to DDCR an error voltage $e_{s,k}$ as:

$$\begin{aligned} e_{s,k}(t, \Theta, \tau) &= \mathcal{I}_k \cdot I_k^* - \mathcal{Q}_k \cdot Q_k^* = \\ &= I_k^* \left\{ (h(\tau))' \cdot [I_k \cdot \cos(\Theta(t)) + Q_k \cdot \sin(\Theta(t))] - (\Theta(t))' \cdot [I_k h(\tau) \cdot \sin(\Theta(t)) - Q_k h(\tau) \cdot \cos(\Theta(t))] \right\} - \\ &- Q_k^* \left\{ (h(\tau))' \cdot [I_k \cdot \sin(\Theta(t)) - Q_k \cdot \cos(\Theta(t))] + (\Theta(t))' \cdot [I_k h(\tau) \cdot \cos(\Theta(t)) + Q_k h(\tau) \cdot \sin(\Theta(t))] \right\} = \\ &= (h(\tau))' \cdot [I_k^2 + Q_k^2] \cdot \cos(\Theta(t)) + (\Theta(t))' \cdot h(\tau) \cdot [I_k^2 + Q_k^2] \cdot \sin(\Theta(t)) \Big|_{I_k=I_k, Q_k=Q} \end{aligned} \quad (9)$$

- the second term of the error voltage may be neglected due to its very small value, which is caused by:

- the assumption that the difference $\delta\omega$ between the frequencies of the received carrier signal ω_c and the locally generated carrier signal ω_1 is very small; usually $\delta\omega$ equals $(10^{-3}-10^{-4}) \omega_s$. moreover, $\delta\omega$ has very small variation in time and therefore the time derivative of $\Theta(t)$ is very small, even if the local carrier is not synchronized
- if the local carrier does not exhibit a $k \cdot 90^\circ$ rotation, and it is synchronized, then $\Theta(t)$ would take very small values, i.e. $\Theta(t) \rightarrow 0$, and hence $\sin(\Theta(t)) \rightarrow 0$.

- under these assumptions the error voltage $e_{s,k}$ expressed by (9) would become:

$$e_{s,k}(t, \Theta, \tau) = (h(\tau))' \cdot A_k^2 \cdot \cos(\Theta(t)) \Big|_{I_k^* = I_k, Q_k^* = Q_k} \quad (10)$$

- the value of the $\cos(\Theta(t))$ function in (10) is positive only if there is no $k \cdot 90^\circ$ rotation, i.e. $\Theta(t)$ belongs to $(-\pi/2; +\pi/2)$, as stated in the second assumption above, which is equivalent to:

$$|\Theta(t)| < \frac{\pi}{2} \quad (11)$$

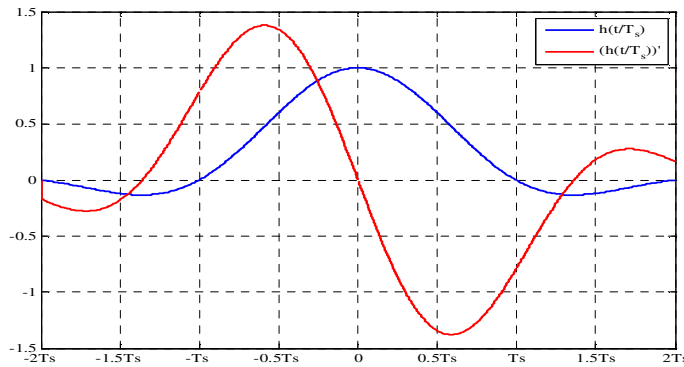

- if condition (11) is observed the sign of the error voltage of (10) is dictated only by the derivative of the function h (the impulse response of the RC filtering characteristic).
 - the impulse response of the RC filter and its first order derivative are shown in figure 8.

Fig.8 Impulse response of the RC filter (blue) and its first order derivative (red)

- the derivative of $h(t)$ equals zero in the probing moment, while the sign of the error voltage $e_{s,k}$ would be positive if the probing were performed **before** the ideal moment and negative if the probing would be performed **after** the ideal moment.

- the sign of the error voltage $e_{s,k}$ can be used to control a symbol-clock synchro circuit.

- the computation of the sign of the error voltage is equivalent to the output of the phase-comparator of the synchro circuit described in the BB lectures. By means of a command circuit it dictates to a controlled divider to perform a phase shift, in advance or delay, of a locally generated symbol clock that has the free-oscillation frequency f_s . The phase-step could be $\Delta\Phi_p = 360^\circ/2^n$, or $\Delta\Phi_p = 360^\circ/N$, using the controlled dividers described in the BB lectures or in the PSK lectures, respectively.

- there should be noted that the error voltage provided by this approach for one symbol period around the probing moment $t = kT_s$ is affected by the signals transmitted in the previous and subsequent symbol periods, because the derivative of $h(t)$ is not zero at $t = kT_s, k \neq 0$, see figure 8.

- so, actually the error voltage is computed so that it would be proportional to $\mathbf{h}(t) \cdot \mathbf{d}(\mathbf{h}(t))/\mathbf{d}t$, which equals zero in every probing moment. This approach also needs to ensure the invariance to the $k \cdot 90^\circ$ rotations. This method will not be dealt with in this course.

- the block diagram of the combined DD-recovery and synchronization of the local carrier and symbol clock is presented in figure 9.

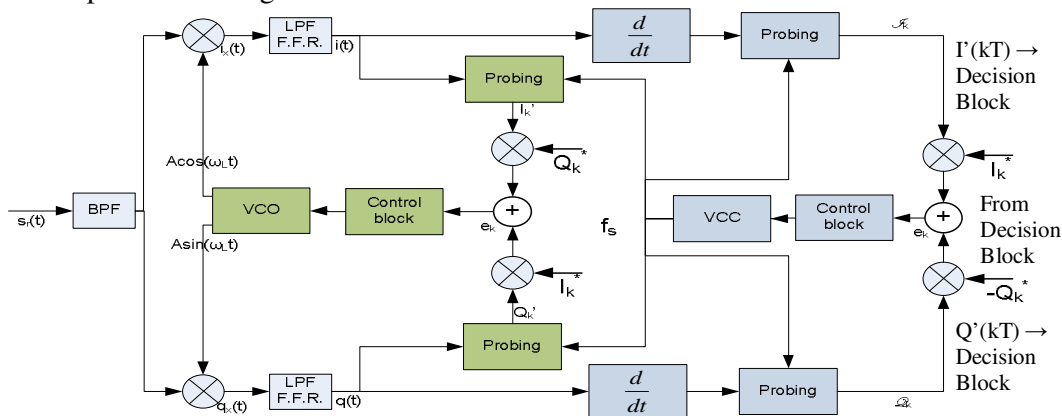

Figure 9. DD-based recovery and synchronization of the local carrier and symbol clock

The Carrierless Amplitude Phase modulation (CAP) -not required for the exam

- the CAP modulation is a particular case of the A+PSK modulation in which the modulating signals are not translated on a carrier frequency; the modulated signal remains, practically, in the baseband. The 90° rotation of the Q modulating signal is accomplished by the employment of a pair of shaping filters with characteristics $f_i(t) = \text{RRC} \cdot \cos \omega_s t$ and $f_q(t) = \text{RRC} \cdot \sin \omega_s t$ in the FB $[\omega_s - \omega_N(1+\alpha), \omega_s + \omega_N(1+\alpha)]$. By subtracting the two filtered signals we get the CAP modulated signal, (12), where * denotes the convolution product.

$$S_{\text{CAP}}(t) = I_k(t) * f_i(t) - Q_k(t) * f_q(t); \quad (12)$$

- these operations are equivalent to a QAM on a carrier frequency equal to f_s , the symbol frequency.

- the demodulation of the CAP signal requires the filtering of the received signal, on two branches, with the

same pair of shaping filters. The $I'(t)$ and $Q'(t)$ resulted signals would be probed with the recovered symbol-clock and fed into the decision, demapping and differential decoding circuits, to get the modulating multibit. -- the block scheme of the CAP demodulator is similar to the one of the QAM demodulator of figure 6, but the multiplications with the local carrier signals and the LPFs are removed, and the FFE and FFR filters would have the $f_i(t)$ and $f_q(t)$ impulse responses.

Error-performances of the ASK+PSK modulation

Symbol-error probability

- the symbol-error probability of the square (n – even) ASK+PSK constellations, can be approximately computed using (13), where the k factor takes different values for a cosine carrier or for a baseband case. The $Q(u)$ function may be approximated by the first term of its Taylor series expansion, see the PSK lectures, the approximation holding for medium and high SNR values. Using this approximation, the symbol-error probability may be computed, for big and medium SNR values, by using (14).

- the symbol-error probability is at first affected by the minimum distance between the constellation vectors, which for square constellations is $\Delta = 2A_0$.

$$p_e = \frac{4(\sqrt{N}-1)}{\sqrt{N}} \cdot Q\left(\frac{\sqrt{2} \cdot A_0}{k \cdot \sigma}\right) = \frac{4(\sqrt{N}-1)}{\sqrt{N}} \cdot Q\left(\sqrt{\frac{6 \cdot P_m}{(N-1) \cdot k^2 \cdot \sigma^2}}\right); \quad k = \sqrt{2} \text{ (on carrier) or } 1 \text{ (in BB)} \quad (13)$$

$$p_e \approx \frac{4(\sqrt{N}-1)}{\sqrt{N}} \cdot \frac{\sqrt{N-1}}{\sqrt{3}} \cdot \frac{e^{-\frac{3}{N-1} \rho}}{\sqrt{2\pi\rho}}; \quad \rho = \frac{2P_m}{k^2 \sigma^2}; \quad k = \sqrt{2} \text{ (on carrier) or } 1 \text{ (in BB)} \quad (14)$$

- for an imposed maximum or average power, Δ_0 depends on the number of vectors in the constellation.

- the $4(L-1)/L$ factor has a small influence upon the p_e ; its values range from 3 ($L=4$) to 4 ($L \rightarrow \infty$).

- *the effect of the number of vectors upon the symbol-error probability, for about the same average power, is difficult to analyze directly, due to the complexity of the $Q(u)$ function.*

- *a simpler evaluation performs the comparison of the SNR values required to ensure the same symbol-error probability for constellations with different number of vectors.*

- so, imposing a target p_{e0} and considering two constellations with N_1 and, respectively $N_2 = 4 \cdot N_1$ vectors, the relation between the SNRs required by the two constellations to ensure p_{e0} can be derived by equaling the arguments of function $Q(u)$, due to the bijectivity of function $Q(u)$, as shown in (15).

$$Q\left(\sqrt{\frac{6 \cdot P_m}{(N_1-1)k^2\sigma_1^2}}\right) = Q\left(\sqrt{\frac{6 \cdot P_m}{(4N_1-1)k^2\sigma_2^2}}\right) \Rightarrow \frac{P_m}{(N_1-1) \cdot \sigma_1^2} = \frac{P_m}{(4N_1-1) \cdot \sigma_2^2} \Rightarrow \frac{P_m}{\sigma_2^2} = \frac{P_m}{\sigma_1^2} \cdot \frac{4N_1-1}{N_1-1} \approx \frac{P_m}{\sigma_1^2} \cdot 4 \Leftrightarrow$$

$$\Leftrightarrow \frac{P_m}{\sigma_2^2} [\text{dB}] = \frac{P_m}{\sigma_1^2} [\text{dB}] + 10 \lg\left(\frac{4N_1-1}{N_1-1}\right) \approx \frac{P_m}{\sigma_1^2} [\text{dB}] + 10 \lg 4 = \frac{P_m}{\sigma_1^2} [\text{dB}] + 6 \text{ dB}; \quad (15)$$

- *the comparison of the SNR values required to ensure the same p_e by two consecutive square QAM constellations, $N_2 = 4N_1$, shows that passing from a given square constellation to the next greater square one requires an increase of 7 dB for 4QAM \rightarrow 16-QAM and then, with the increase of N_1 , the SNR increase tends to 6 dB.*

- the computation of the p_e of the „cross” constellations is more complex. Due to the odd number of bits/symbol ($n=5, 7, 9$), this signal should not be considered as being composed of two similar ASK signals.

- literature shows that the symbol-error probabilities of these constellations are upper-bounded by:

$$p_e \leq 4 \cdot Q\left(\frac{A_0}{\sigma}\right) = 4 \cdot Q\left(\sqrt{\frac{6 \cdot P_m}{(N-1) \cdot k^2 \cdot \sigma^2}}\right) \approx 4 \cdot \frac{\sqrt{N-1}}{\sqrt{3}} \cdot \frac{e^{-\frac{3}{N-1} \rho}}{\sqrt{2\pi\rho}}; \quad k = \sqrt{2} \text{ (on carrier) or } 1 \text{ (BB)} \quad (16)$$

- expressions (13) and (16) show that „cross” constellations have the same argument of the $Q(u)$ as the square ones.

- when passing from a square constellation to the upper „cross” one, the number of vectors is double, $N_2 = 2N_1$, and the factor $(\sqrt{N}-1)/\sqrt{N}$ of (13) can be approximated by unity; the SNR increase to ensure the same symbol-error probability is computed by:

$$\frac{P_m}{\sigma_2^2} = \frac{P_m}{\sigma_1^2} \cdot \frac{2N_1-1}{N_1-1} \approx \frac{P_m}{\sigma_1^2} \cdot 2 \Leftrightarrow \frac{P_m}{\sigma_2^2} [\text{dB}] = \frac{P_m}{\sigma_1^2} [\text{dB}] + 10 \lg\left(\frac{2N_1-1}{N_1-1}\right) \approx \frac{P_m}{\sigma_1^2} [\text{dB}] + 10 \lg 2 = \frac{P_m}{\sigma_1^2} [\text{dB}] + 3 [\text{dB}]; \quad (17)$$

- using the considerations above and (17) one may conclude that *when doubling the number of vectors of a constellation, the SNR increase, required to provide the same p_e , may be approximated with 3 dB for high values of N . The transitions of $N = 4 \rightarrow 8$ and $N = 8 \rightarrow 16$ would need SNR increases of 3.7 and 3.3 dB.*

- *the greater the value of N , the smaller the approximation error*

- table 1 shows the variation of the SNR when doubling the number of vectors in the QAM constellation; it is represented both linearly and logarithmically, starting from $N = 4$.

N	4	8	16	32	64	128	256
$(2N-1)/(N-1)$	1	2,33	2,14	2,06	2,03	2,015	2,007
$10 \cdot \lg[(2N-1)/(N-1)]$ [dB]	0	3,68	3,31	3,15	3,08	3,04	3,02

Table 1.
Values of the SNR increases when doubling the QAM constellations

The bit-error probability

- for medium and high SNR values we may assume that, with a very great probability, a symbol is mistaken for one of its neighboring symbols.

- assuming a perfect Gray mapping of the multibit, the neighboring symbols differ by only one bit and the bit-error probability may be approximated by:

$$p_b \approx \frac{P_e}{\log_2 N} = \frac{P_e}{n}; \quad (18)$$

- for a non-perfect Gray mapping, e.g. „cross” constellations with great N , the value provided by (18) should be increased by a factor that equals the average number of bits-difference between two neighboring vectors, the average being made on the whole constellation. This factor is rather small, smaller than 2, and does not modify significantly the bit-error probability; in almost all applications its effect may be neglected.

- figure 10 presents the bit-error probability vs. SNR curves ensured by the QAM constellations with $N = 4, 8, 16, 32, 64, 128, 256$, together with the one provided by the 2-PSK constellation, considered as reference. The curves are obtained by simulating the transmission and the Gaussian noise and not by computations using (13) or (16).

- the differential encoding of the first two bits of the multibit, employed to ensure constellations invariant to the $k \cdot 90^\circ$ rotations, increases the number of bit errors, for the same number of symbol errors. Some considerations about this process would be presented in the DT lectures.

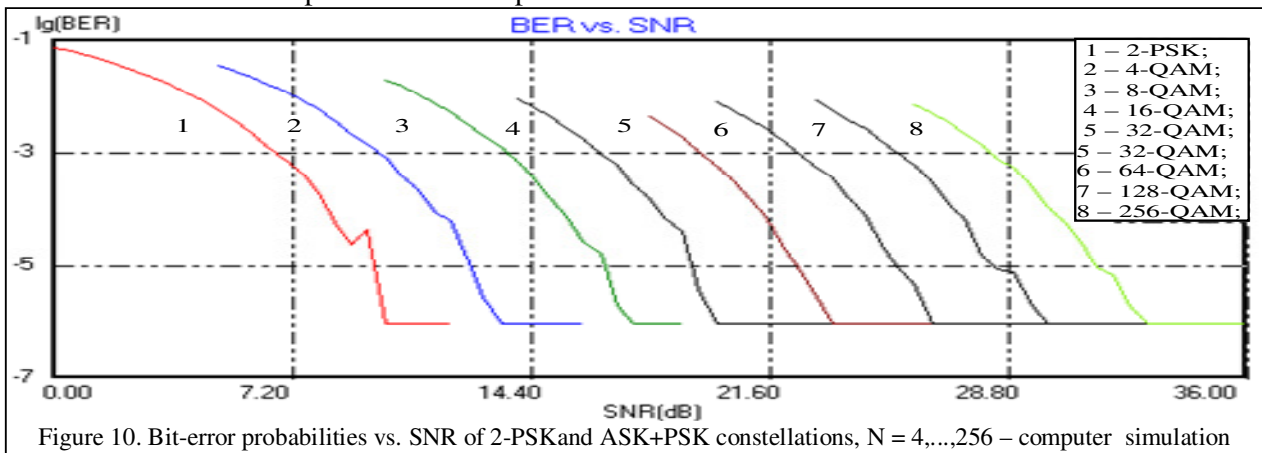

Figure 10. Bit-error probabilities vs. SNR of 2-PSK and ASK+PSK constellations, $N = 4, \dots, 256$ – computer simulation

Comparison between the SNR values required by the N -A+PSK, N -PSK, and N -ASK to ensure the same symbol-error probability.

- we consider relations (19) (see PSK lectures), which express the symbol-error probabilities of the N -PSK, and (13) and (16), expressing those probabilities of the square and „cross” N -QAM constellations, where $k^2 = 2$ to ensure the same SNR as for the PSK modulations.

$$p_{eP-N} \approx \operatorname{erfc}\left(\sqrt{\rho} \sin \frac{\pi}{N}\right) = 2Q\left(\sqrt{2\rho \sin^2 \frac{\pi}{N}}\right) \approx \frac{e^{-\rho \sin^2 \frac{\pi}{N}}}{\sqrt{\pi\rho} \sin \frac{\pi}{N}}; \quad N \geq 4; \quad p_{eP-2} = Q(\sqrt{2\rho}); \quad N = 2; \quad (19)$$

- the symbol-error probability of ASK vs. SNR for N vectors (levels) is expressed by (20), see the PAM and ASK lectures:

$$p_{e-A} = \frac{2(N-1)}{N} Q \left(\sqrt{\frac{6P_m}{(N^2-1)\sigma^2}} \right) \approx \frac{2(N-1)}{N} \cdot \frac{\sqrt{N^2-1}}{\sqrt{6}} \cdot e^{-\frac{6}{N^2-1} \frac{\rho}{2}}; \quad \rho = \frac{P_m}{\sigma^2} \quad (20)$$

- the factors $4(\sqrt{N}-1)/\sqrt{N}$ or 4 of the square or cross A+PSK constellations (see (13) or (16)) range between 2 and 4 with N
- the factor $2(N-1)/N$ of ASK, see (20), ranges from 1 to 2 with N and will be considered approximately equal to the factor 2 of PSK, see (48)
- for an approximate analysis the three factors mentioned above will be considered equal since their impact upon the SNR values at which these modulations provide a certain value of p_e is very small, especially for small p_e values.
- the comparison considers the 2-PSK modulation as reference and is made by computing the SNR values needed by each modulation, i.e., PSK, A+PSK and ASK to ensure the same value of the symbol-error probability p_e , in terms of N, the number of vectors in the constellation.
- to this end, we will first show that the SNR needed by 2-ASK to ensure a given p_e is the same as the one needed by 2-PSK, see (21).

$$p_{eQ}(2) = Q(\sqrt{2\rho_P}) = Q(\sqrt{2\rho_A}) = p_{eA}(2) \quad (21)$$

- this can be explained by the fact that the two modulations provide practically the same signal, i.e.:

$$\begin{aligned} s_{2PSK}(t) &= A \cos(\omega_c t + k \cdot \pi) = \pm A \cos \omega_c t; k \in \{0,1\}; \\ s_{2ASK}(t) &= A_k \cos \omega_c t = \pm A \cos \omega_c t; A_k \in \{-A, +A\}; \end{aligned} \quad (22)$$

- the SNR increases required by the ASK modulation to ensure the same p_e when the constellation is doubled, i.e. from N points to 2N points is derived in (23)

$$\begin{aligned} p_{eA}(N) &\approx Q \left(\sqrt{\rho_{A-N} \cdot \frac{3}{N^2-1}} \right) = Q \left(\sqrt{\rho_{A-2N} \cdot \frac{3}{(2N)^2-1}} \right) \approx p_{eA}(2N) \Rightarrow \\ \frac{\rho_{A-2N}}{\rho_{A-N}} &= \frac{4N^2-1}{N^2-1} \Rightarrow \text{SNR}_{A-2N} = \text{SNR}_{A-N} + 10 \lg \left(\frac{4N^2-1}{N^2-1} \right) \end{aligned} \quad (23)$$

- there should be noted that the SNR increase needed by ASK when the number of points in the constellation is doubled equals 7 dB for 4-ASK, compared to 2-ASK and approximately 6 dB when doubling constellations with $N \geq 4$

- then we derive compute the SNR increases needed by PSK modulations to ensure the same p_e when the number of points N_1 of a constellation is doubled to $N_2=2N_1$, by using (19), and we get (24).

$$\begin{aligned} p_{eQ}(N_1) &\approx Q \left(\sqrt{2\rho_{P-N_1} \cdot \sin^2 \frac{\pi}{N_1}} \right) = Q \left(\sqrt{2\rho_{P-2N_1} \cdot \sin^2 \frac{\pi}{2N_1}} \right) \approx p_{eQ}(2N_1) \Rightarrow \\ \frac{\rho_{P-2N_1}}{\rho_{P-N_1}} &= \frac{\sin^2 \frac{\pi}{N_1}}{\sin^2 \frac{\pi}{2N_1}} = 4 \cos^2 \frac{\pi}{2N_1} \Rightarrow \text{SNR}_{P-2N} = \text{SNR}_{P-N} + 10 \lg \left(4 \cos^2 \frac{\pi}{2N_1} \right) \end{aligned} \quad (24)$$

- the SNR increases needed by PSK range from 3dB, for 4-PSK compared to 2-PSK, to 5.3 dB, for-8-PSK compared to 4-PSK, and to 6 dB for 2N-PSK compared to N-PSK, for $N \geq 8$.

- the same analysis was made above for the A+PSK (QAM) modulations, see (17), and is recalled here for convenience as (25). Note that for A+PSK, N should be greater than 4.

$$\frac{\rho_{Q-2N}}{\rho_{Q-N}} = \frac{2N-1}{N-1} \Rightarrow \text{SNR}_{Q-2N} = \text{SNR}_{Q-N} + 10 \lg \left(\frac{2N-1}{N-1} \right); \quad N \geq 4 \quad (25)$$

- the SNR increases needed by A+PSK modulations to ensure the same p_e when the number of points in constellation is doubled range from 3.7 dB, for 8-QAM compared to 4-QAM, to 3.3 dB for 16-QAM compared to 8-QAM, and to 3 dB for $N \geq 16$.

- the values of the SNR increases, $\Delta \text{SNR}(N)$ in dB, needed by the A+PSK, PSK and ASK modulations for several values of N are summarized for comparison in table 5, considering as reference SNR_{ref} , the SNR value required by 2-PSK to ensure the desired value of p_e , i.e. p_{e0} .

- for ASK the increases values are computed using the SNR needed by 2-ASK compared to 2-PSK (SNR_{ref}),

see (20) and (21), and then using (23)

- for PSK and A+PSK (QAM) they were computed using (24) and, respectively, (25) and the fact that 4-PSK and 4-QAM need the same SNRs to ensure a given p_e .

Modulation \downarrow N \rightarrow	2	4	8	16	32	64
A+PSK	-	+3	+6.7	+10	+13	+16
PSK	SNR _{ref}	+3	+8.3	+14.2	+20.2	+26.2
ASK	SNR _{ref}	+7	+13.2	+19.2	+25.2	+31.2

Table 5. SNR increases $\Delta\text{SNR}(N)$ of A+PSK (Q), PSK (P) and ASK (A) to ensure a given p_e , referred to the SNR needed by 2-PSK

- the actual SNR required by one of the modulations for a given N and at an imposed value of p_e can be computed by computing the SNR needed by 2-PSK to ensure that value of p_e (by using the first term of (21), by computing the SNR increase $\Delta\text{SNR}_{Q,P,A}(N)$, required by the desired constellation and order, using (23), or (24) or (25), and the summing the two values, i.e.:

$$\text{SNR}_{Q,P,A}(N)|_{p_{e0}} = \text{SNR}_{2\text{-PSK}}|_{p_{e0}} + \Delta\text{SNR}_{Q,P,A}(N) \quad (26)$$

- for example, if we need the SNR required by 64-QAM to ensure $p_{e0} = 10^{-5}$, we compute using (19) that 2-PSK requires approximately SNR_{ref} ≈ 9.5 dB to provide p_{e0} and add it to the $\Delta\text{SNR}_Q(16)$, i.e. 16 dB, and we get SNR_{16Q} ≈ 25.5 dB to ensure p_{e0} .

- note that for N = 4 the A+PSK and PSK modulations have similar performances.

- for N > 4, the SNRs required by the N-PSK constellations to ensure a given p_e , are higher than those required by the corresponding N-A+PSK constellations to ensure the same symbol-error probability.

- this is because, for the same average power, the minimum distance of the N-A+PSK constellation is greater than the one of the N-PSK constellation, and therefore when doubling the number of points, the A+PSK requires a SNR increase of only approximately 3 dB, while the N-PSK requires a SNR increase of approximately 6 dB.

- comparing now ASK and PSK, we note that for N=2 the ASK requires the same SNR as 2-PSK; then, when doubling the constellation to N = 4, the ASK requires 7 dB, compared to the 3 dB needed by PSK, and then, for N ≥ 4 , when the constellation order is doubled, both modulations require $\Delta\text{SNR}(N)$ values approximately equal to 6 dB.

- the considerations above show that the A+PSK modulations outperform the PSK modulations in transmissions with more than 2 bits/symbol.

- the ASK modulations require greater SNRs than the ones required by the PSK modulations with the same number of vectors for N > 2, to ensure the same symbol-error probability.

- so, we may conclude that A+PSK modulation provides the best performance, while the ASK modulation ensures the „poorest” performance, out of the three modulations.

Applications of the A + PSK modulations

- these modulations are employed in digital transmissions with medium and high bit rates on vocal-telephone channels, on terrestrial radio and satellite channels, on mobile and nomadic radio channels and on cable channels.

- the constellations with N > 16 are employed only together with error-correcting codes, due to their small minimum Euclidean distances (distance imposed by the maximum allowed average power), which leads to relatively high symbol-error rates.

Applications on vocal-telephone channels

- a non-coded 16-QAM modulation was employed in the transmissions with $D \leq 9600$ bps, on these channels, as specified by the ITU-T V.22bis, V.29 and V. 32 Recommendations.

- higher order QAM constellations are employed in transmissions according to the ITU-T, V.32 bis, V.33, Recommendations, with bit-rates $D \leq 14.400$ bps, V.34 Recommendation, with $D \leq 33.600$ bps, V.90 Recommendation, $D \leq 56$ kbps and V.92 Recommendation, $D \leq 64$ kbps.

- due to their small minimum Euclidean distance, these constellations should be employed in combination with an error-correcting code, within the TCM coded modulations, see the DT lectures.

- benefiting of the optimized QAM constellations and the error-correcting codes, the TCM coded modulations reach extremely high spectral efficiencies, up to 16 bps/Hz, while ensuring a BER < $1 \cdot 10^{-5}$.

Applications on fixed terrestrial and satellite radio channels

- the square 16-QAM, 64-QAM and even 256-QAM constellations are employed adaptively, besides the variants of the QPSK modulation (OQPSK and $\pi/4$ -QPSK), in single-carrier transmissions between radio relays, providing bit-rates of up to 155.52 Mbps, i.e. the transmission of a STM-1 stream.

- the square 16-QAM and 64-QAM constellations are also employed adaptively, besides the variants of the QPSK modulation (OQPSK and $\pi/4$ -QPSK), in the multi-carrier transmissions (OFDM) of the broadcasted digital TV signals, DVB, and digital audio signals, DAB, both on terrestrial radio channels (DVB-T), and on satellite channels (DVB-S).
- to ensure a low error probability the QAM constellations are coded with convolutional codes, in DVB-T, DAB and DVB-S1; nowadays, these codes are replaced by the LDPC codes, in DVB-S2 and DVB-T.

Applications on nomadic and mobile radio channels

- the QPSK, 16-QAM and 64-QAM modulations are employed in transmissions to the nomadic users, acc. to the 802.11 IEEE standard series, both in single-carrier, variant b., and multi-carrier (OFDM), variant a., g. and n transmissions; the second one could provide bit rates up to 54 Mbps, in terms of the parameters of the radio channel, while the latter also includes MIMO techniques.
- the QPSK and 16-QAM modulations are also employed in mobile transmissions according to the 3GPP standard, providing bit rates of up to 384 kbps/subscriber.
- in the above transmissions, the QAM constellations are also used in combinations with error-correcting codes.
- the multi-carrier OFDM transmissions, employing the QPSK, 16 and 64-QAM constellations on each sub-carrier, are standardized for the downlink and uplink connections of the 4G (LTE and LTE-A and WiMax) systems, being able to provide bit-rates of up to 100 Mbps/radio carrier.
- some basic notions regarding the adaptive employment of the QAM modulations on fixed and mobile radio channels would be presented in the DT lectures.

Applications on cable channels

- the QAM modulations are employed in the subscriber-loop transmissions on twisted copper wires, provided by the xDSL systems.
- the HDSL system employs the 16 or 64-CAP modulations;
- the ADSL system employs the multi-tone (DMT)- QAM transmissions, using constellations from 2-PSK up to 4096-QAM to provide bit rates up to 6 Mbps (downstream) and 512 kbps (upstream), by using 256 tones;
- the VDSL system employs constellations with up to 32768-QAM in DMT-QAM with 1000 tones on the transmitting path, providing bit rates of up to 30 Mbps per path with a BER $< 1 \cdot 10^{-7}$
- both A and VDSL employ error-correcting codes and the QAM constellations are employed adaptively, according to the cable attenuation.
- an older version of ADSL technology uses the CAP modulation
- more details regarding the xDSL systems will be provided in the Telephony and Data Transmissions courses
- the QAM modulations are also employed in digital transmissions over the coaxial cables.